

SCHMIEDEEISEN DESIGNSERIE »ROKOKO«

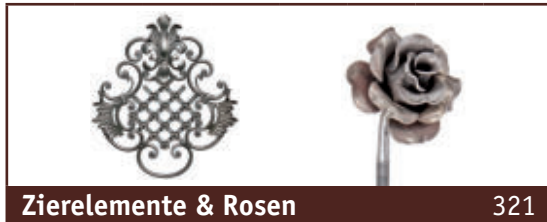

Zierelemente & Rosen

321

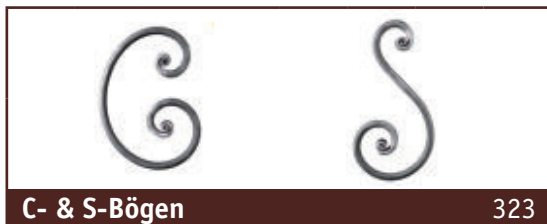

C- & S-Bögen

323



Designstäbe vierkant & rund

322



SCHMIEDEEISEN DESIGNSERIE »ROKOKO«

 glatt, verwendetes Bundmaterial bei Lieferung: 15 x 3 mm, zweirillig,
(Abbildungen zeigen teilweise einfaches, ungerilltes Bundmaterial)

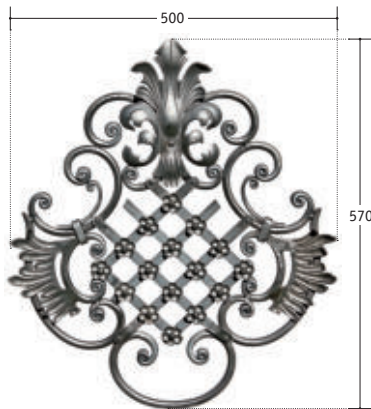

Zierornament »Rokoko«, rund

Art. Nr.	Material	kg
93 12 28	● 12	6,0



Blumenblatt »Rokoko«,
Materialstärke: 4 mm

Art. Nr.	kg
93 12 39	0,14



Blume Calla »Rokoko«,
Materialstärke: 4 mm.
Blume und Docht

Art. Nr.	kg
93 12 40	0,18

HINWEIS:

Sämtliche Artikel der
Designserie »Rokoko«
auch in Material 16 x 8
erhältlich.

Bitte Lieferzeiten erfragen.

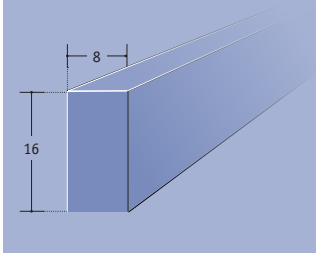

Zierkrone »Rokoko«,
groß mit Blume

Art. Nr.	Material	kg
93 12 25	● 12 	11,8



Zierornament »Rokoko«, rund

Art. Nr.	Material	kg
93 12 20	● 12 	11,4



Rose »Rokoko«, Stiel: Ø 7 mm

Art. Nr.	Typ	kg
93 12 15	A (ohne Knospenblatt)	0,20
93 12 16	B (mit Knospenblatt)	0,25

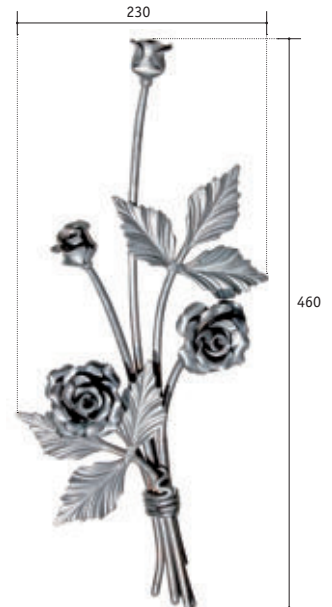









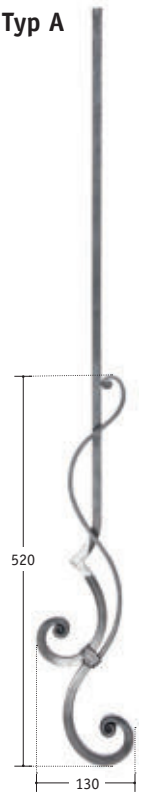









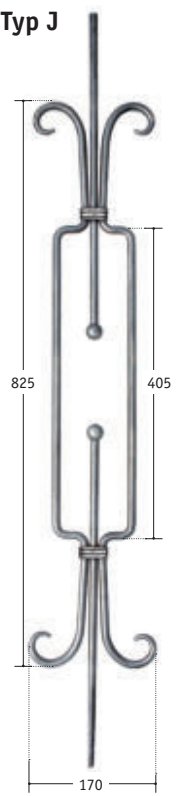

Rosengebinde »Rokoko«

Art. Nr.	kg
93 12 17	1,10

SCHMIEDEEISEN DESIGNSERIE »ROKOKO«

 glatt, verwendetes Bundmaterial bei Lieferung: 15 x 3 mm, zweirillig
(Abbildungen zeigen tlw. einfaches, ungerilltes Bundmaterial)

<p>Typ A</p>  <p>↓ gerillt - zweirillig ↓</p> <p>520</p> <p>130</p> <p>Art. Nr. 93 86 60  ■ 12 2,19 kg</p>	<p>Typ B</p>  <p>650</p> <p>165</p> <p>Art. Nr. 93 86 61  ■ 12 2,14 kg</p>	<p>Typ C</p>  <p>656</p> <p>105</p> <p>Art. Nr. 93 86 62  ■ 12 2,52 kg</p>	<p>Typ G</p>  <p>600</p> <p>140</p> <p>Art. Nr. 93 12 30  ● 12 1,90 kg</p>	<p>Typ H</p>  <p>290</p> <p>130</p> <p>Art. Nr. 93 86 63  ● 12 1,30 kg</p>	<p>Typ I</p>  <p>440</p> <p>180</p> <p>Art. Nr. 93 86 65  ● 12 1,80 kg</p>
---	---	---	---	---	---

<p>Typ J</p>  <p>↓ gerillt - zweirillig ↓</p> <p>825</p> <p>405</p> <p>170</p> <p>Art. Nr. 93 86 67  ● 12 2,79 kg</p>	 <p>625</p> <p>115</p> <p>Art. Nr. 93 12 08  ● 12 1,70 kg</p>	 <p>635</p> <p>175</p> <p>Art. Nr. 93 12 09  ● 12 2,30 kg</p>	 <p>625</p> <p>100</p> <p>Art. Nr. 93 12 07  ● 12 1,51 kg</p>
---	--	--	--



HINWEIS:

Sämtliche Artikel der Designserie »Rokoko« auch in Material 16 x 8 erhältlich.

Bitte Lieferzeiten erfragen.

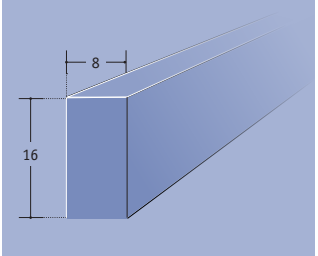

SCHMIEDEEISEN DESIGNSERIE »ROKOKO«

glatt, verwendetes Bundmaterial bei Lieferung: 15 x 3 mm, zweirillig,
(Abbildungen zeigen tlw. einfaches, ungerilltes Bundmaterial)

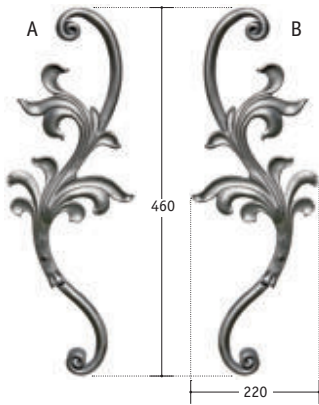

S-Bogen »Rokoko«

Art. Nr.	Material	Typ	kg
93 12 35	● 12	A	1,80
93 12 36	● 12	B	1,80



Zierelement »Rokoko«

Art. Nr.	Material	kg
93 12 31	● 12	1,9

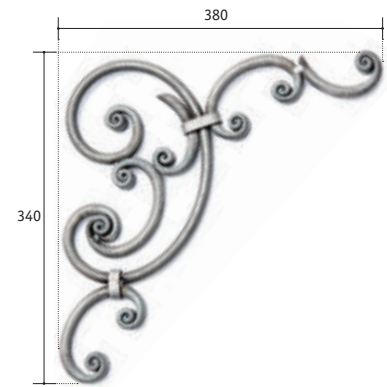

Eckverzierung »Rokoko«

Art. Nr.	Material	kg
93 12 18	● 12	2,0



Doppel-C-Bogen »Rokoko«

Art. Nr.	Material	kg
93 12 32	● 12	2,0

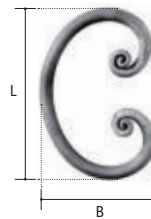

C-Bogen, glatt

Art. Nr.	Material	L x B	kg
93 90 22	● 12	110 x 75	0,28
93 90 23		160 x 105	0,45
93 90 24		195 x 125	0,55
93 90 25		290 x 205	1,05

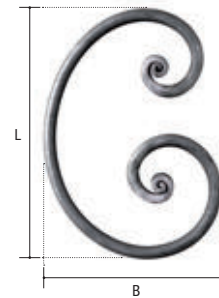

C-Bogen in Nierenform, glatt

Art. Nr.	Material	L x B	kg
93 90 13	● 12	160 x 110	0,45
93 90 14		240 x 165	0,74
93 90 15		310 x 210	0,95

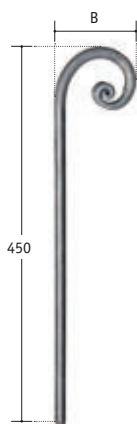

Anschlussbogen »Rokoko«

Art. Nr.	Material	B	kg
93 12 12	● 12	45	0,50
93 12 13		85	0,60
93 12 14		165	0,70



S-Bogen, glatt

Art. Nr.	Material	L x B	kg
93 91 57	● 12	235 x 100	0,54
93 91 58		275 x 135	0,67

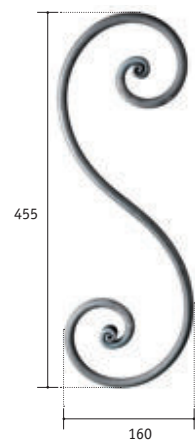

S-Bogen, glatt,
Enden gleich eingerollt

Art. Nr.	Material	kg
93 91 59	● 12	1,05

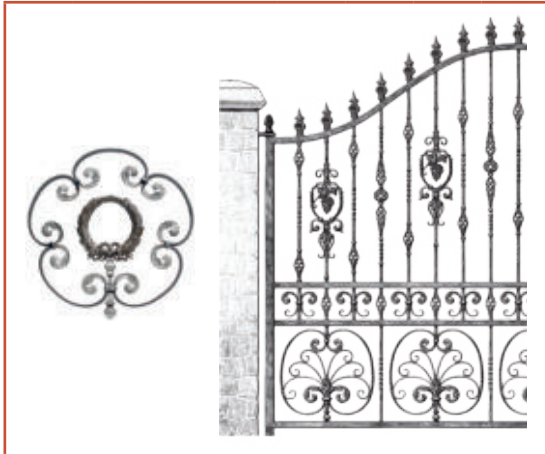

Zierelemente & Anwendungen 326, 328, 329



Zierstäbe & Zierteile 327, 329, 331



Zierelemente 328 - 330, 332



Zwischen- & Anfangsstäbe 326 - 327, 330 - 331



Zierelemente & Geländerstäbe 332 - 333

SCHMIEDEEISEN DESIGNSERIE »MOZART«



 Sphäro- und Graugussteile
nicht feuerverzinkbar, nicht schweißbar!

Material:  glatt

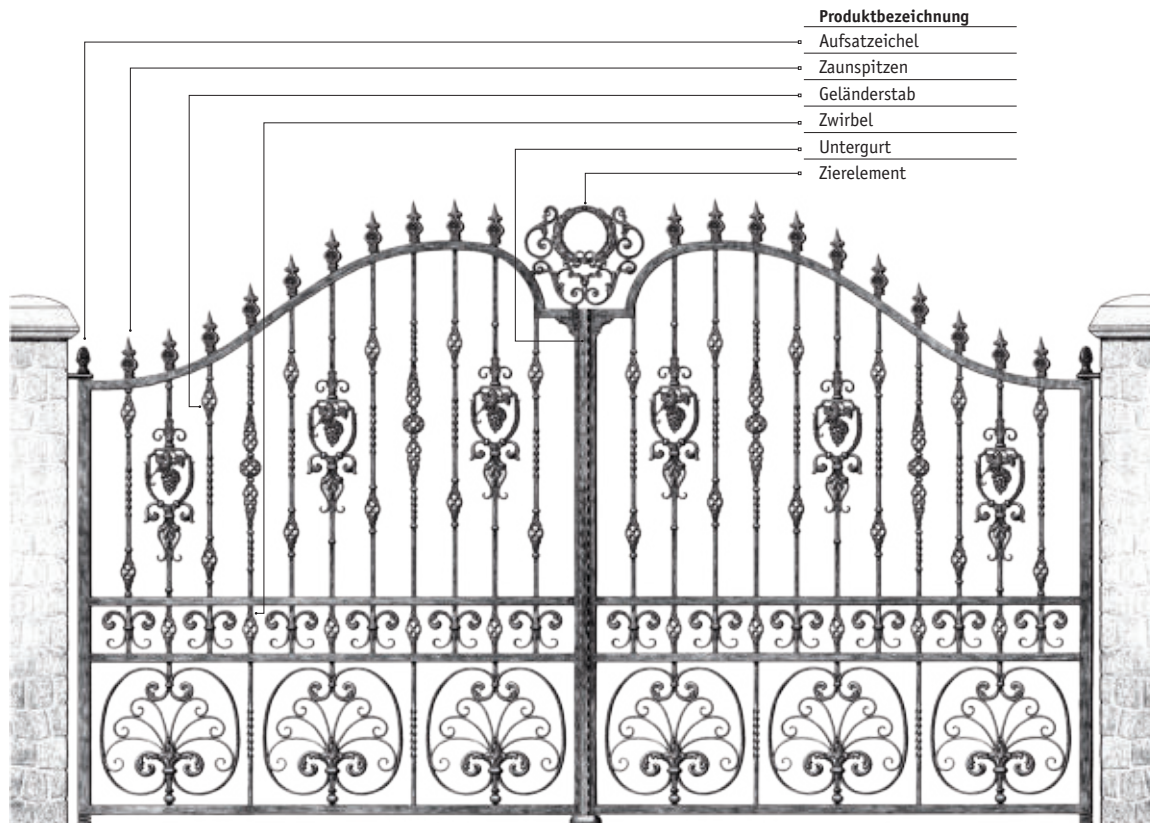

Zierelement

Art. Nr.	Material	kg
93 13 00	 16 x 8 + ● 8	3,73

Zierelement, mit Kranz

Art. Nr.	Material	kg
93 13 01	 16 x 8	6,38

Anfangsstab, Typ »Prestige«

Art. Nr.	kg
93 13 65	27,5

SCHMIEDEEISEN DESIGNSERIE »MOZART«

 Sphäro- und Graugussteile
nicht feuerverzinkbar, nicht schweißbar!

Material:  glatt



Weintraubenstab,
aus Schmiedeeisen

Art. Nr.	Material	kg
93 13 13	 ■ 14	4,07

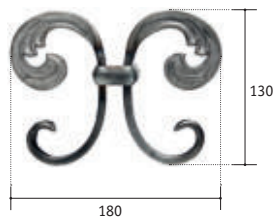

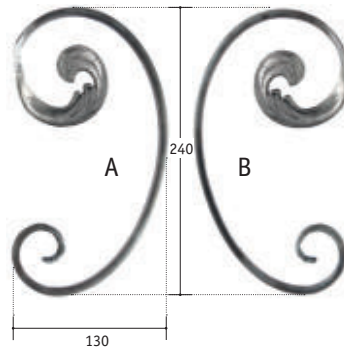

Zierornament, vorgebunden

Art. Nr.	Material	kg
93 13 14	 ■ 14 x 6	0,44



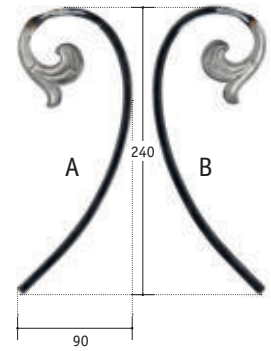

Zierornament

Art. Nr.	Material	kg
A 93 13 07	 ■ 14 x 6	0,46
B 93 13 08	 ■ 14 x 6	



Zierornament

Art. Nr.	Material	kg
A 93 13 05	 ■ 14 x 6	0,28
B 93 13 06	 ■ 14 x 6	

Zierelemente aus Schmiedeguss (Sg), roh, doppelseitig verwendbar.
Materialstärke: 4 mm. Biegsam bei rotglühender Erhitzung.
Geeignet zum Schweißen und Feuerverzinken.

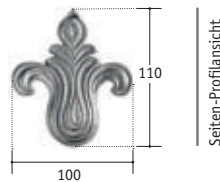

Akanthusblatt (Sg)

Art. Nr.	Material	kg
93 13 31	4 mm	0,14

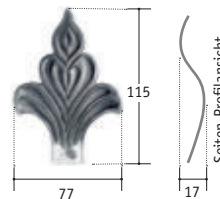

Akanthusblatt (Sg)

Art. Nr.	Material	kg
93 13 30	4 mm	0,14

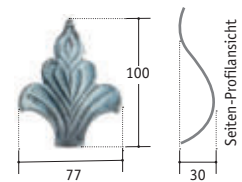

Akanthusblatt (Sg)

Art. Nr.	Material	kg
93 13 29	4 mm	0,14



Akanthusblatt (Sg)

Art. Nr.	Material	kg
93 13 35	4 mm	0,22



Akanthusblatt (Sg)

Art. Nr.	Material	kg
93 13 32	4 mm	0,13

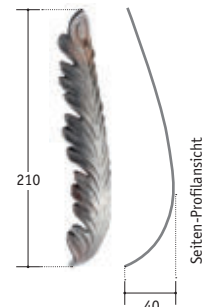

Akanthusblatt (Sg)

Art. Nr.	Material	kg
93 13 34	4 mm	0,24



Akanthusblatt (Sg)

Art. Nr.	Material	kg
93 13 33	4 mm	0,13

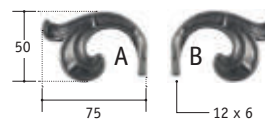

Akanthusblatt (Sg)

Art. Nr.	Material	kg
A 93 13 40	4 mm	0,07
B 93 13 41		

SCHMIEDEEISEN DESIGNSERIE »MOZART«

 Sphäro- und Graugussteile
nicht feuerverzinkbar, nicht schweißbar!

Material:  glatt

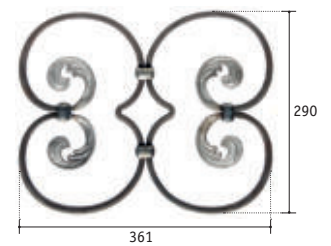
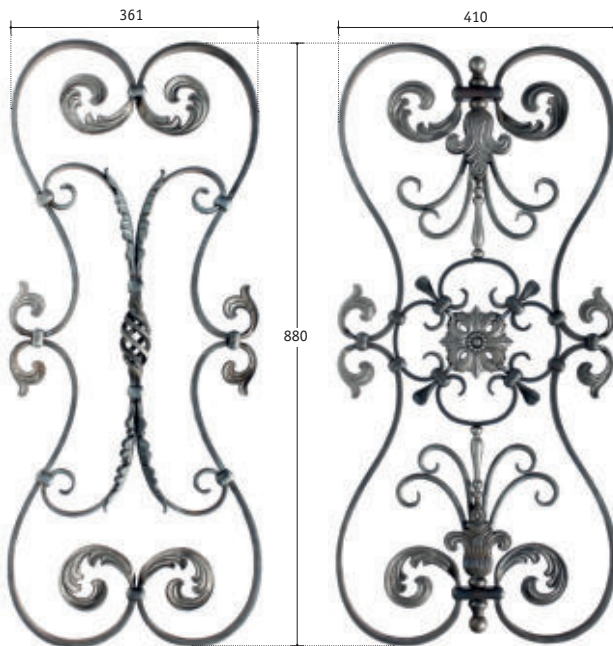

Zierornament

Art. Nr.	Material	kg
93 13 15	 16 x 8	2,77

Zierelement

Art. Nr.	Material	kg
93 13 17	 16 x 8	5,5

Zierelement

Art. Nr.	Material	kg
93 13 16	 16 x 8	7,88

SCHMIEDEEISEN DESIGNSERIE »MOZART«

⚠ Sphäro- und Graugussteile
nicht feuerverzinkbar, nicht schweißbar!

Material:  glatt

Produktbezeichnung

- Zieraufsätze
- Zaunspitzen
- Zierrosetten
- Geländerstab
- Zierelement
- Blenden
- Traversen

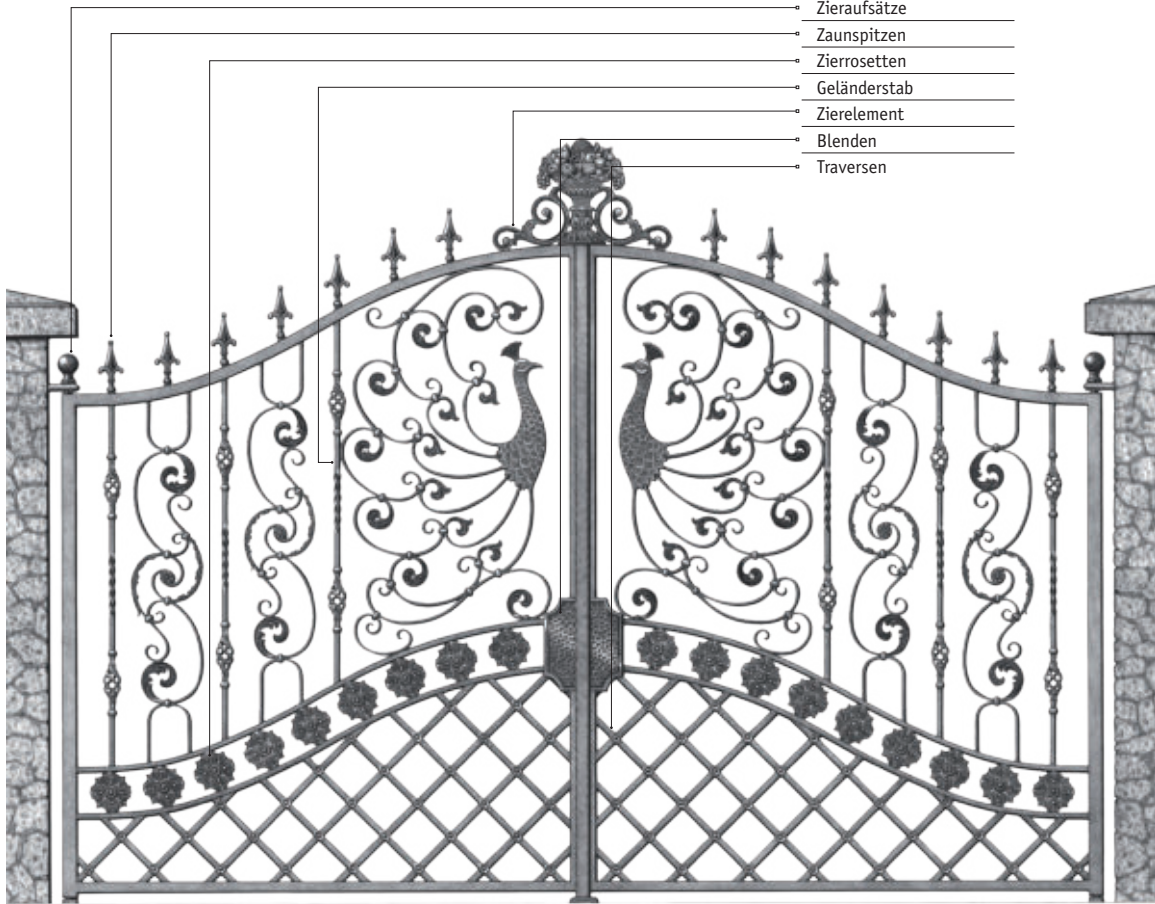

↑ Zierelement

Art. Nr.	Material	kg
93 13 10	 14 x 6	8,73



Zierelement »Pfau« aus Schmiedeguss (Sg)

Art. Nr.	kg
93 13 38	2,84

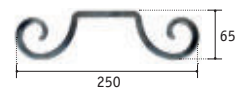
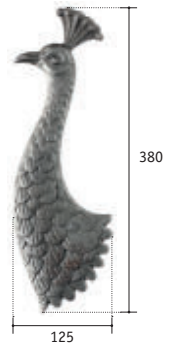

↑ Zierelement

Art. Nr.	Material	kg
93 13 12	 16 x 8	0,47

← Zierstab

Art. Nr.	Material Mitte	kg
93 13 02	 16 x 8	3,5

SCHMIEDEEISEN DESIGNSERIE »MOZART«

 Sphäro- und Graugussteile nicht feuerverzinkbar, nicht schweißbar!

Material:  glatt

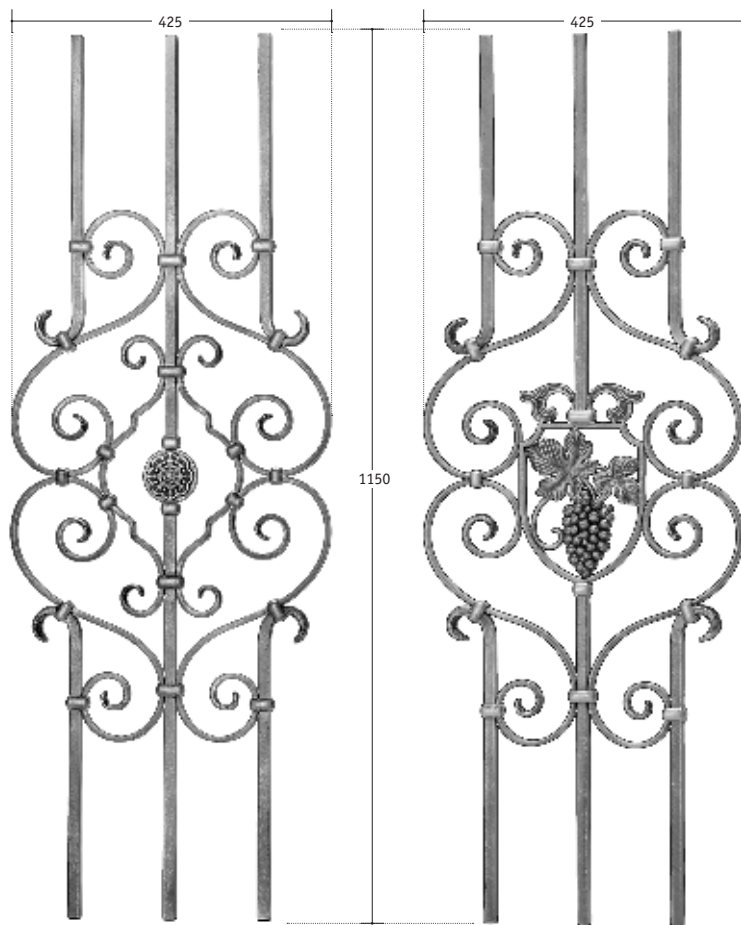

Zierelement mit Blumenornament

Art. Nr.	kg
93 13 66	9,45

Zierelement mit Traubenornament

Art. Nr.	kg
93 13 67	9,45

Mittelstücke für Anfangsstäbe → (Sphäroguss), zum Einschrauben

Art. Nr.	kg
A 93 13 23	6,85
B 93 13 24	7,55

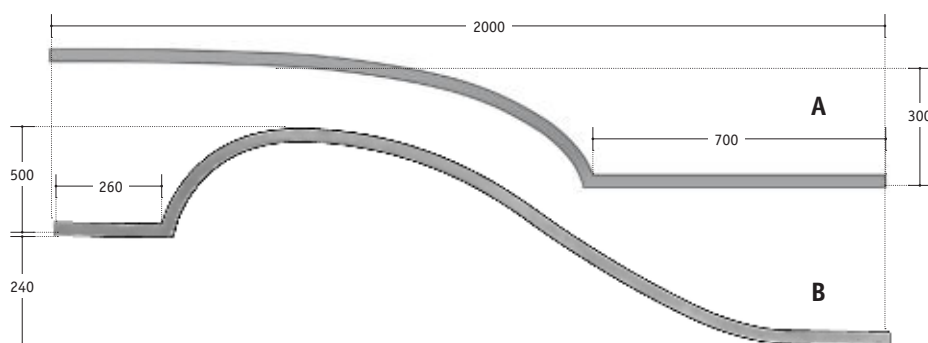

Rohrbogen

Art. Nr.	Maße
A 93 13 70	40 x 30 x 2,5
B 93 13 71	40 x 30 x 2,5



Zieraufsatz, klein

Art. Nr.	Material	kg
93 13 04	 14 x 6	1,07

Zieraufsatz-Set für Tore, groß, bestehend aus 4 Einzelteilen

Art. Nr.	Material	kg
93 13 18	 16 x 8	5,3



Längenmaß bezieht sich auf den mittig montierten Zustand

⚠ Sphäro- und Graugussteile
nicht feuerverzinkbar, nicht schweißbar!

Material: glatt



Zwischen- und Anfangsstäbe, Mittelteil aus Sphäroguss. Endstücke aus Stahl (schweißbar). Rosetten aus Grauguss (nicht schweißbar und nicht verzinkbar).

	Art. Nr.	Material oben/unten	mit Rosette	kg
A	93 13 25	■ 14 / ■ 14	-	2,08
B	93 13 26	● 16 / ■ 16	-	2,23
C	93 13 28	■ 30 / ■ 35	✓	11,8
D	93 13 27	● 35 / ■ 35	✓	13,0

Zierstäbe, Schmiedeeisen

	Art. Nr.	Material oben/unten/Mitte	kg
E	93 13 03	■ 14 / ■ 14 / ■ 16 x 8	4,09
F	93 13 11	■ 14 / ■ 14 / ■ 16 x 8	4,13
G	93 13 09	■ 16 x 8	5,41

SCHMIEDEEISEN DESIGNSERIE »MOZART«

 Sphäro- und Graugussteile
nicht feuerverzinkbar, nicht schweißbar!

Material:  glatt



Zierelement

Art. Nr.	Material	kg
93 13 19	 16 x 8	15,29

Zierelemente aus Schmiedeguss (Sg),
roh, doppelseitig verwendbar.
Biegsam bei rotglühender Erhitzung.
Geeignet zum Schweißen und Feuerverzinken.

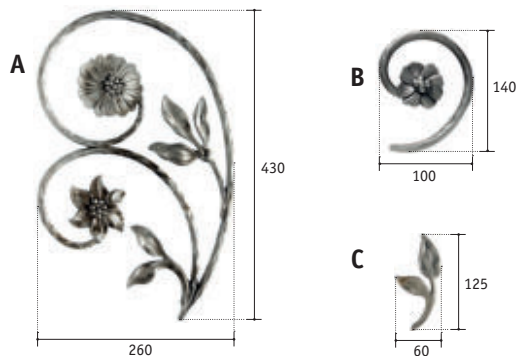

Zierelemente (Sg)

	Art. Nr.	kg
A	93 13 39	2,18
B	93 13 37	0,41
C	93 13 36	0,16



Zierelement „Blume“ mit Rahmen, doppelseitig

Art. Nr.	Material	kg
93 13 57	 16 x 8	11



Zierelement »Mozart«, einseitig

Art. Nr.	kg
93 13 63	2,46



Zwirbel-Zapfen

Art. Nr.	Material	kg
93 13 56	14	0,35



Zwirbel

Art. Nr.	Material	kg
93 13 55	14	0,30

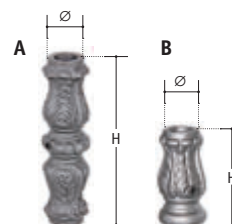



Zierhülse, Grauguss

	Art. Nr.	für Profil	ø x H	kg
A	93 13 54	● 14	32 x 115	0,29
B	93 13 53	● 14	30 x 60	0,14

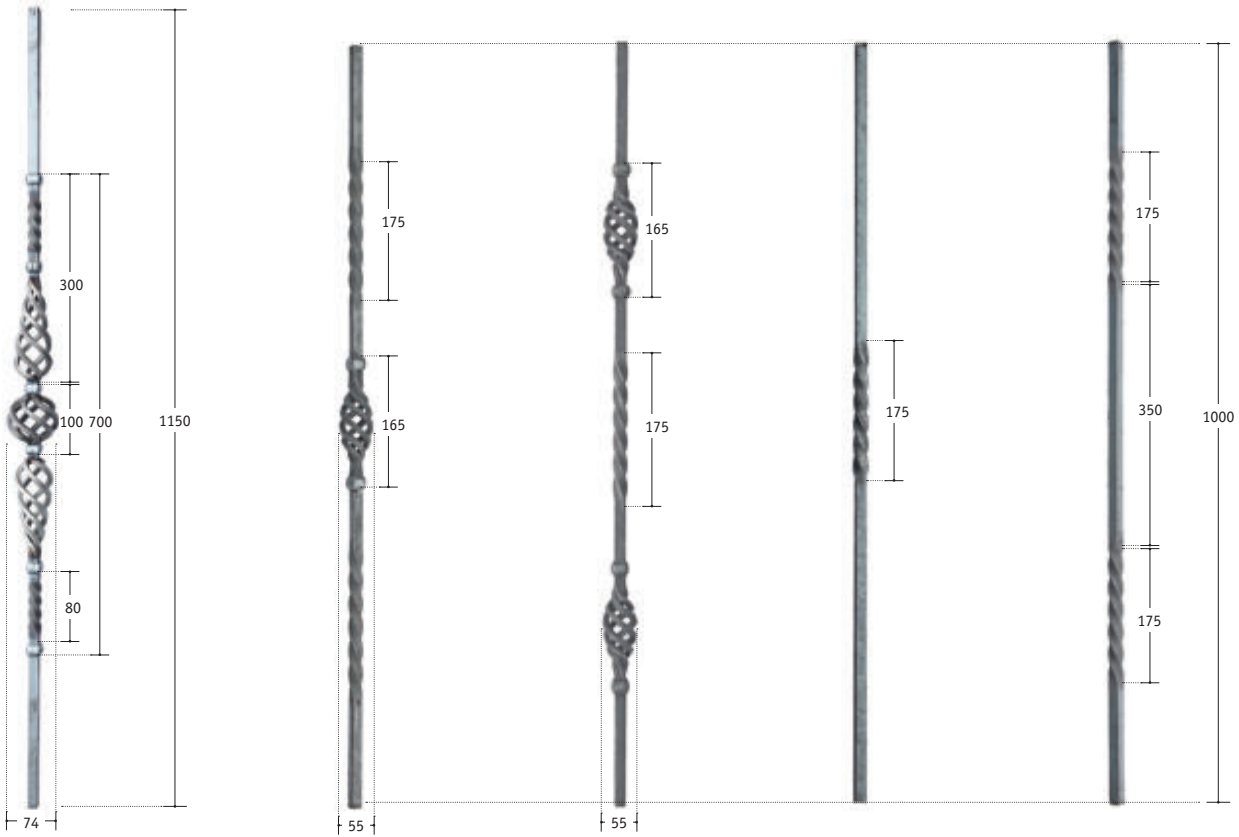
Geländerstäbe, Länge: 1000 & 1150 mm,  glatt



Art. Nr. 93 13 50
 | ■ 14 |
L: 1150 mm | 2,2 kg

Art. Nr. 93 13 48
 | ■ 14 | 1,66 kg
L: 1000 mm

Art. Nr. 93 13 49
 | ■ 14 | 1,74 kg
L: 1000 mm

Art. Nr. 93 13 46
 | ■ 14 | 1,432 kg
L: 1000 mm

Art. Nr. 93 13 47
 | ■ 14 | 1,488 kg
L: 1000 mm

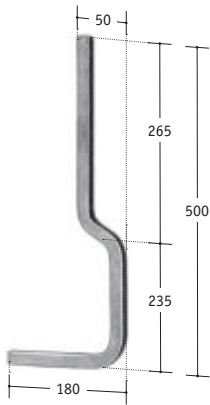

Untergurtstütze

Art. Nr.	Material	kg
93 13 68	 ■ 20	2,11

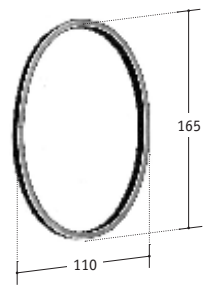



Ring oval glatt

Art. Nr.	Material	kg
93 91 09	■ 12 x 6	0,16



Zierelement X-Form

Art. Nr.	Material	L x B	kg
93 13 51	 ■ 14 x 6	230 x 125	0,34
93 13 52	 ■ 16 x 8	275 x 150	0,63

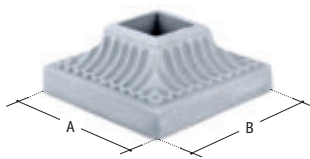

Abdeckkrosette »Mozart«

Art. Nr.	für Stab	A x B	kg
93 13 64	■ 14	50 x 50	0,36
93 13 59	■ 30	90 x 90	0,36
93 13 60	■ 35	90 x 90	0,45



Geländerstabumbau

Art. Nr. 93 13 61
 | ■ 16 x 8 |
B: 770 x 170 mm | 1,68 kg

Art. Nr. 93 13 62
 | ■ 16 x 8 |
B: 820 x 170 mm | 1,79 kg

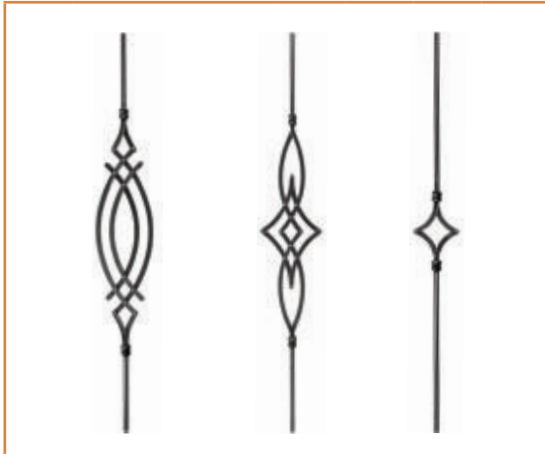

Designstäbe »Toscana«

336



Elementeserie »Rosa«

337



Elementeserie »Paradiso & Flora«

338



Zierteile »Florenz«

339

SCHMIEDEEISEN DESIGNSERIE »FLORENZ«



SCHMIEDEEISEN DESIGNSERIE »FLORENZ«

Material:  glatt, leicht geschmiedet

Schmiedeeisen Designserie »Florenz«

Diese Designserie eignet sich besonders zur Herstellung von Zäunen, Geländern und Toren, die damit zu einem besonderen Blickfang werden. Die aufwendig gefertigten Elemente »Rosa«, »Paradiso« und »Flora« mit

ihren floralen Ornamenten in italienischem Stil werden sich von gewöhnlichen Zäunen, Geländern und Toren durch ihre besondere Wertigkeit und ihr exklusives Aussehen abheben.

Geländerstäbe, Länge: 1000 mm,  glatt, leicht geschmiedet
Stäbe »Toscana«, **Kunstmotiv handgenietet** in 12 x 5 mm Flacheisen

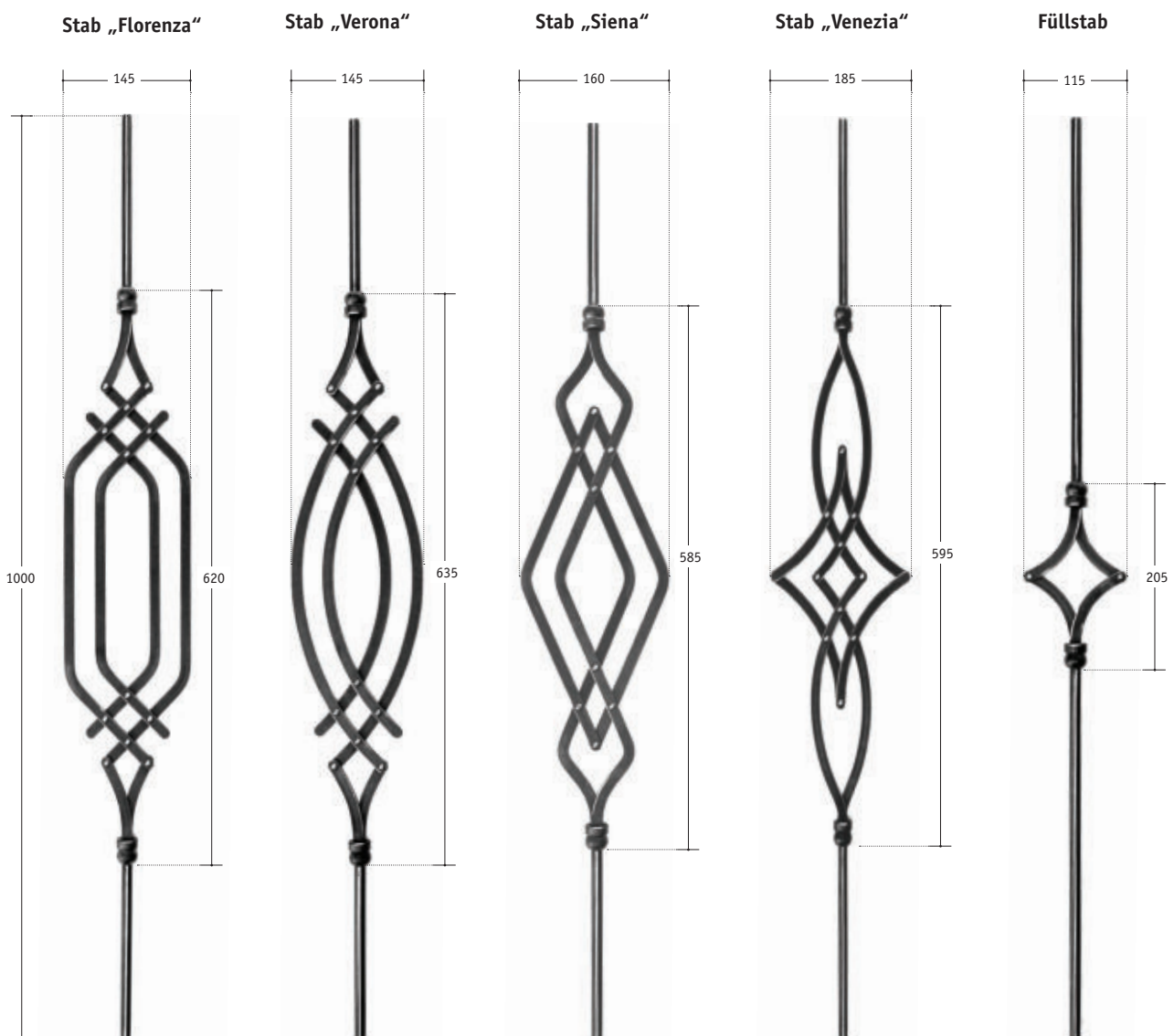

Art. Nr. 93 11 33
 | ● 12 | 1,55 kg

Art. Nr. 93 11 34
 | ● 12 | 1,52 kg

Art. Nr. 93 11 35
 | ● 12 | 1,48 kg

Art. Nr. 93 11 36
 | ● 12 | 1,44 kg

Art. Nr. 93 11 37
 | ● 12 | 1,06 kg

Material:  glatt, leicht geschmiedet

Zierelement »Rosa«,
Materialstärken:
Ø 10 und 12 mm 

Art. Nr.		kg
93 11 49	A	2,6
93 11 50	B	2,6

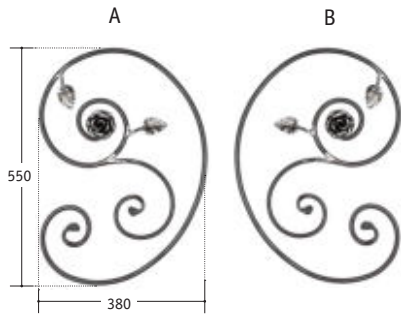

Stabranke »Rosa« (ohne Stab),
Materialstärke: Ø 10 mm 

Art. Nr.	kg
93 11 59	1,55

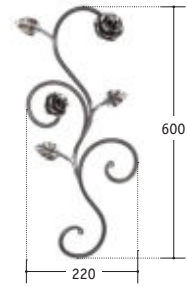

Zierelement »Rosa«,
Materialstärke: Ø 12 mm 

Art. Nr.		kg
93 11 51	A	1,68
93 11 52	B	1,68

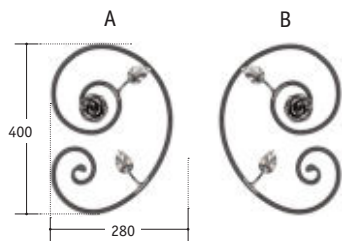

Zierelement »Rosa«,
Materialstärken:
Ø 8 und 12 mm 

Art. Nr.		kg
93 11 53	A	1,68
93 11 54	B	1,68

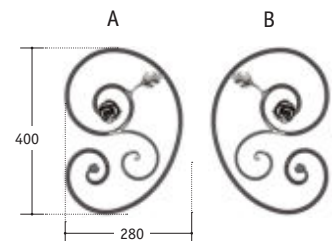

Zierelement »Rosa«,
Materialstärke: Ø 12 mm 

Art. Nr.		kg
93 11 55	A	1,44
93 11 56	B	1,44

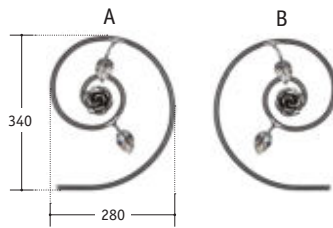

Zierelement »Rosa«,
Materialstärke: Ø 10 mm 

Art. Nr.		kg
93 11 57	A	1,44
93 11 58	B	1,44

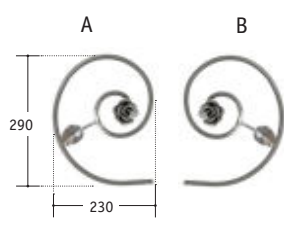

Motiv »Rosa« (groß),
Materialstärken:
Ø 8, 10 und 12 mm 

Art. Nr.	kg
93 11 46	5,36

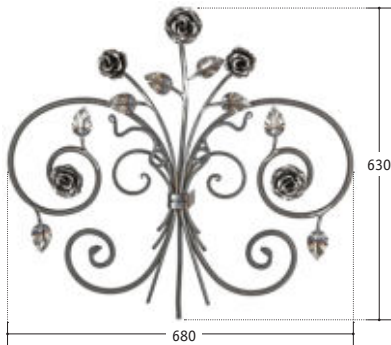

Motiv »Rosa« (klein),
Materialstärken:
Ø 8 und 10 mm 

Art. Nr.	kg
93 11 45	2,45

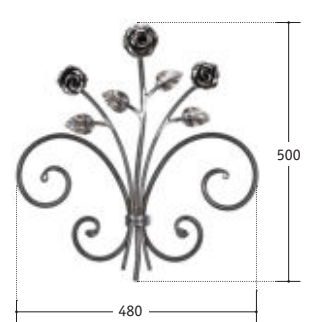

Bildmotiv »Rosa« (groß),
Material Ringe: 16 x 8 mm 

Art. Nr.	kg
93 11 47	10,52



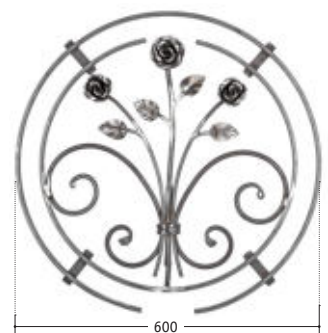

Bildmotiv »Rosa« (klein),
Material Ringe: 16 x 8 mm 

Art. Nr.	kg
93 11 48	5,90



SCHMIEDEEISEN DESIGNSERIE »FLORENZ«

Material:  glatt, leicht geschmiedet

Motiv »Paradiso« (groß),
Materialstärken: \varnothing 8 mm,
 \varnothing 10 mm, und \varnothing 12 mm 

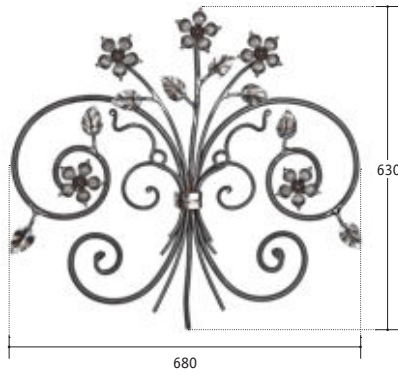

Art. Nr.	kg
93 11 27	5,46

Motiv »Paradiso« (klein),
Materialstärken:
 \varnothing 8 mm und \varnothing 10 mm 

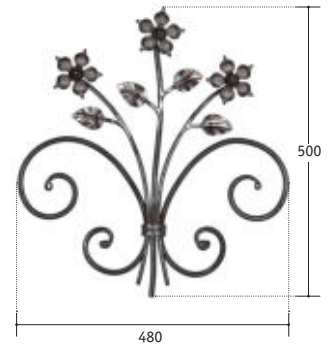

Art. Nr.	kg
93 11 24	2,60

Bildmotiv »Paradiso« (groß),
Material Ringe:
16 x 8 mm 



Art. Nr.	kg
93 11 25	10,62

Bildmotiv »Paradiso« (klein),
Material Ringe: 16 x 8 mm 

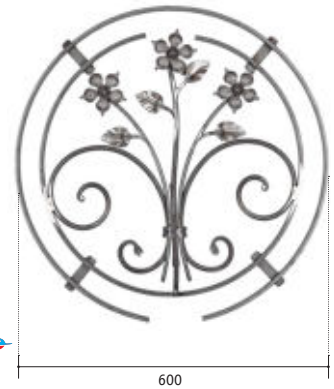

Art. Nr.	kg
93 11 26	6,05

Stabranke »Flora« (ohne Stab),
Materialstärke: \varnothing 10 mm 



Art. Nr.	kg
93 11 39	1,30

Zierelement »Flora«,
Materialstärke der Bögen: \varnothing 12 mm 

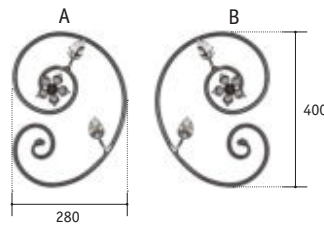

Art. Nr.	kg
93 11 04	A 1,64
93 11 05	B 1,64

Zierelement »Flora«,
Materialstärken der Bögen:
 \varnothing 10 mm und \varnothing 12 mm 

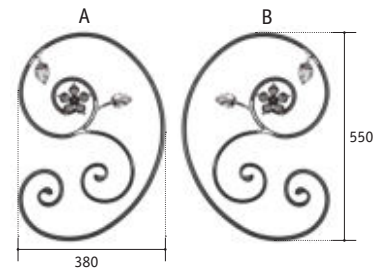

Art. Nr.	kg
93 11 00	A 2,46
93 11 01	B 2,46

Zierelement »Flora«,
Materialstärke: \varnothing 10 mm 

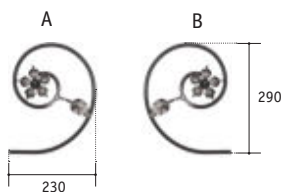

Art. Nr.	kg
93 11 16	A 0,75
93 11 17	B 0,75

Zierelement »Flora«,
Materialstärke: \varnothing 12 mm 

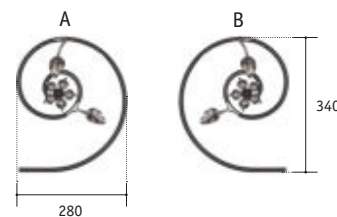

Art. Nr.	kg
93 11 12	A 1,30
93 11 13	B 1,30

Zierelement »Flora«,
Materialstärken: \varnothing 8 mm und \varnothing 12 mm 

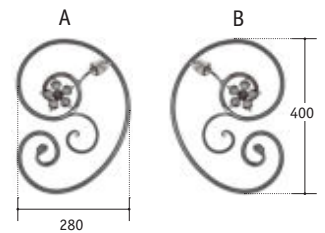

Art. Nr.	kg
93 11 08	A 1,68
93 11 09	B 1,68

SCHMIEDEEISEN DESIGNSERIE »FLORENZ«

Material:  glatt, leicht geschmiedet

Füllschnörkel 1, 
Materialstärke: \varnothing 12 mm

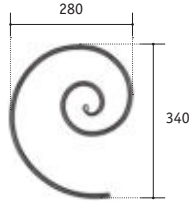

Art. Nr.	kg
93 11 23	1,10

Füllschnörkel 2, 
Materialstärke: \varnothing 10 mm

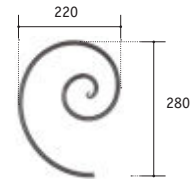

Art. Nr.	kg
93 11 22	0,60

Füllschnörkel 3, 
Materialstärke: \varnothing 10 mm

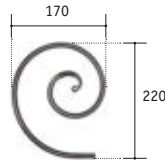

Art. Nr.	kg
93 11 21	0,48

Füllschnörkel 4, 
Materialstärke: \varnothing 8 mm

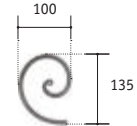

Art. Nr.	kg
93 11 20	0,16

Motiv »Lilie«, 
(ohne Stab),
Materialstärke \varnothing 10 mm

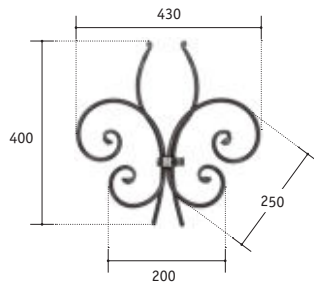

Art. Nr.	kg
93 11 38	1,60

Blatt »Florenz«
Materialstärke: 4 mm

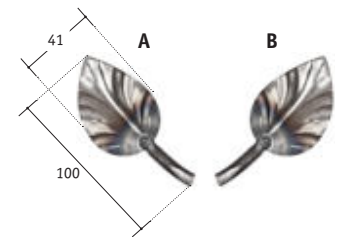

Art. Nr.	Ausrichtung
93 11 64	links (A)
93 11 65	rechts (B)



Abschlussstück,
mit Innensechskant M4
(Feststellschraube)

Art. Nr.	für Stab
93 11 32	\varnothing 12

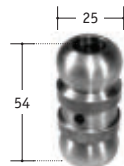

Einschraubstück,
mit Innensechskant M4
(Feststellschraube)

Art. Nr.	für Stab
93 11 31	\varnothing 12



Einschraubstück,
mit Innensechskant M4
(Feststellschraube)

Art. Nr.	für Stab
93 11 61	\varnothing 12

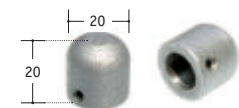

Abschlussstück,
mit Innensechskant M4
(Feststellschraube)

Art. Nr.	für Stab
93 11 40	\varnothing 12

Flacheisen,  Länge: 2000 mm,
Lochabstand: 132 mm, Loch- \varnothing : 12,5 mm

Art. Nr.	Material	kg
91 10 96	25 x 6	2,5
91 10 97	25 x 8	3,0



Anwendungsbeispiel: Geländer

Zierelement »Flora«	Art. Nr. 93 11 00/01
Zierelement »Flora«	Art. Nr. 93 11 08/09
Bildmotiv »Paradiso«	Art. Nr. 93 11 26
Füllschnörkel 3	Art. Nr. 93 11 21

SCHMIEDEEISEN DESIGNSERIE »LOTUS«



Fertigelemente

341

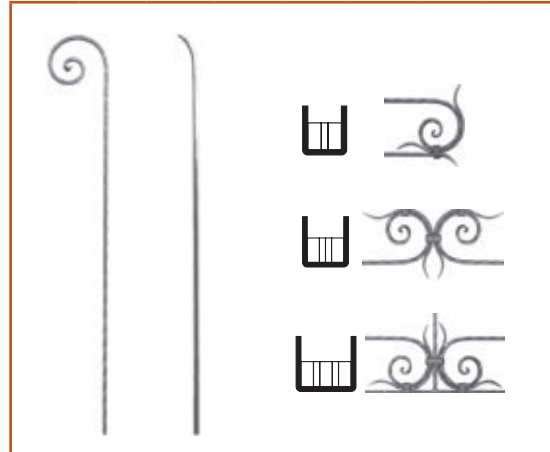

Stäbe & Bündchen

341

Zierelemente „Lotus“

Mit Fertigelementen der Schmiedeeisen Designserie »Lotus« lassen sich schnell kunstvolle Tore, Zäune oder Geländer herstellen. Durch die Möglichkeit, einzelne Basisteile der Serie »Lotus« zu bestellen und miteinander zu kombinieren, können immer wieder ganz individuelle Entwürfe entstehen.

Anwendungsbeispiele

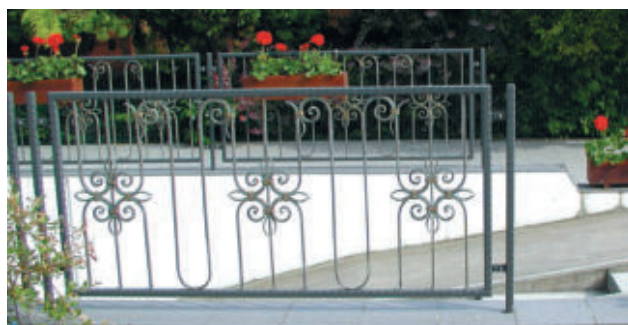

SCHMIEDEEISEN DESIGNSERIE »LOTUS«

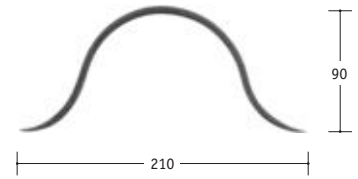
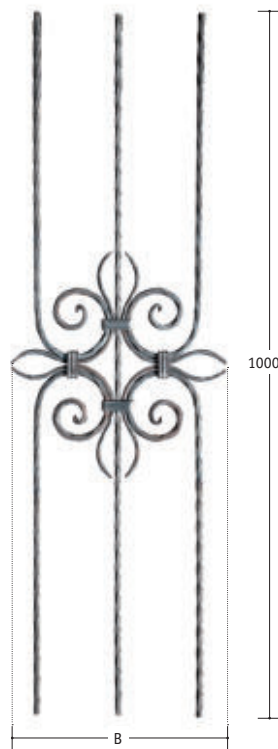
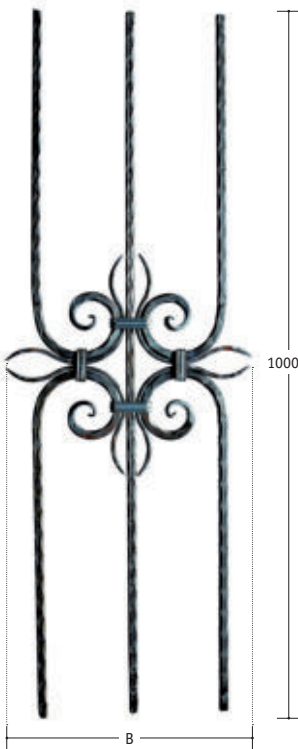

Ziermantel, glatt

Art. Nr.	Material	g
93 88 20	16 x 5	174



Bündchen „Lotus“ 50 Stk./Beutel

Art. Nr.	Material	kg
93 35 05	16 x 8 + 16 x 5 + 16 x 8	1,7



Bündchen „Lotus“ 50 Stk./Beutel

Art. Nr.	Material	kg
93 35 04	16 x 8 + 16 x 5 + 16 x 5 + 16 x 8	1,9



Bündchen „Lotus“ 50 Stk./Beutel

Art. Nr.	Material	kg
93 35 03	16 x 8 + 16 x 5 + 16 x 8 + 16 x 5 + 16 x 8	2,3



Flacheisen, beidseitig kantengehämmert

Art. Nr.	Material	Länge
93 88 13	16 x 8	3000

Lotus Fertigelement, Ziermantel aus 12 x 5 mm

Art. Nr.	Material	Oberfläche	B	kg
93 88 28	12	gehämmert	340	5,20
93 88 25	12	glatt	315	5,50

Lotus Fertigelement, Ziermantel aus 16 x 8 mm

Art. Nr.	Material	Oberfläche	B	kg
93 88 26	16 x 8	gehämmert	330	5,08
93 88 27	16 x 8	glatt	310	5,00

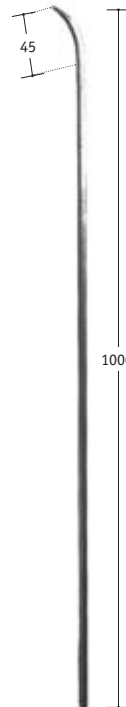
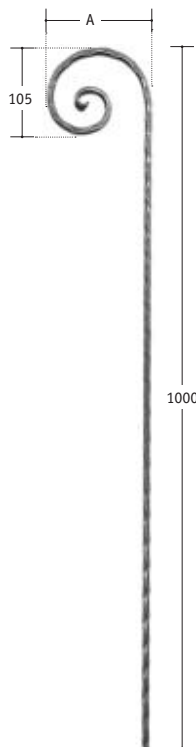
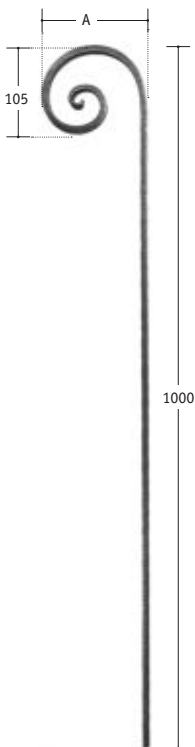

Schneckenstab, glatt

Art. Nr.	Material	A	kg
93 88 21	16 x 8	105	1,3
93 88 18	12	125	1,3

Schneckenstab, kantengehämmert

Art. Nr.	Material	A	kg
93 88 17	12	125	1,3

Kröpfstab, glatt

Art. Nr.	Material	kg
93 88 23	16 x 8	1,0



Stäbe & Designelemente 344 - 345

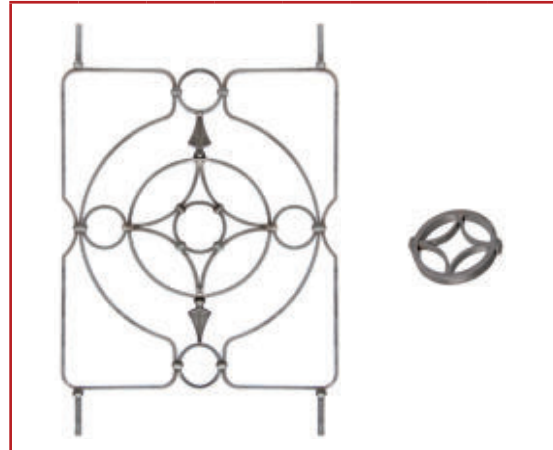

Elemente & Rosetten 344 - 345

SCHMIEDEEISEN DESIGNSERIE »CITY«



Material:  glatt, leicht geschmiedet

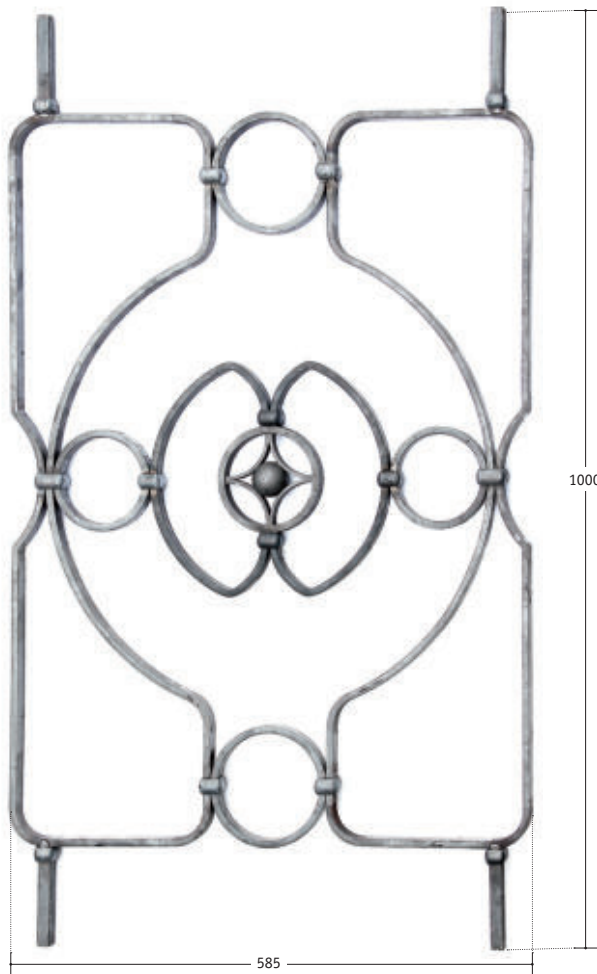

Art. Nr. 93 15 06
 | ■ 14
L: 1000 mm | 10 kg



Art. Nr. 93 15 04
 | ■ 14
L: 950 mm | 2,04 kg



Art. Nr. 93 15 00
 | ■ 14
L: 950 mm | 2,24 kg



Art. Nr. 93 15 02
 | ■ 14
L: 950 mm | 2,44 kg

Art. Nr. 93 15 05
 | ■ 14
L: 1000 mm | 2,14 kg

Art. Nr. 93 15 01
 | ■ 14
L: 1000 mm | 2,34 kg

Art. Nr. 93 15 03
 | ■ 14
L: 1000 mm | 2,54 kg



Material:  glatt, leicht geschmiedet

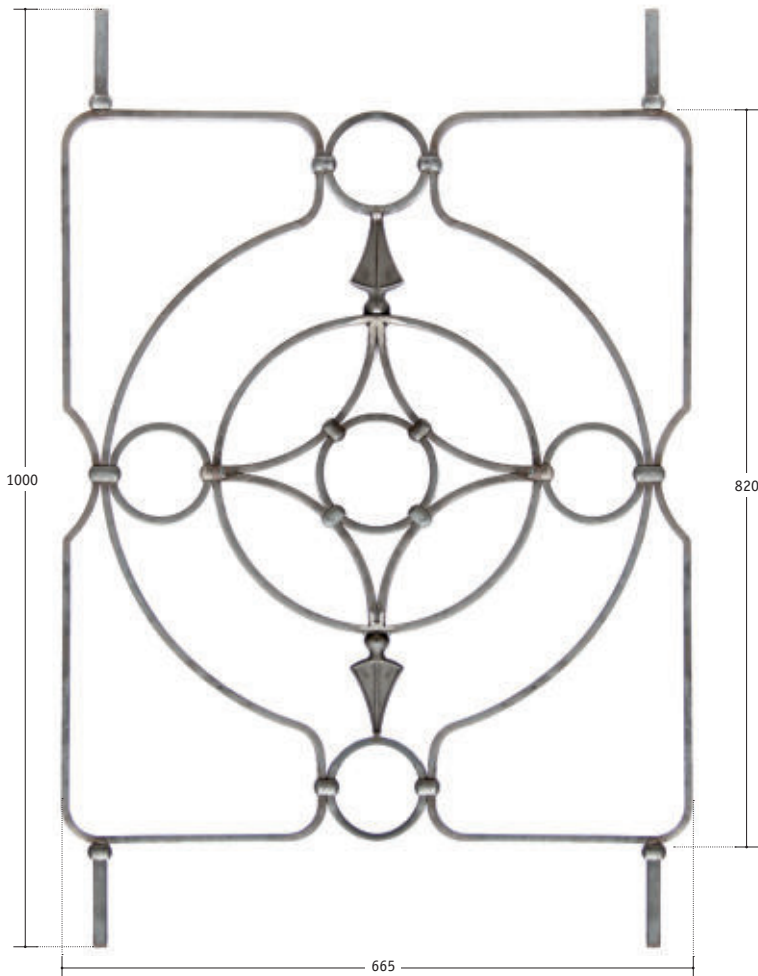

Art. Nr. 93 15 07
 | ■ 14
L: 1000 mm | 10 kg

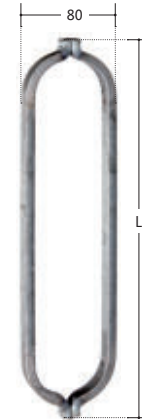

Art. Nr. 93 15 08
 | ■ 16 x 8
L: 315 mm | 0,70 kg

Art. Nr. 93 15 09
 | ■ 16 x 8
L: 340 mm | 0,80 kg

Zierelement "City", offen

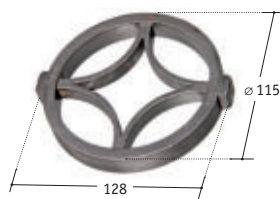

Art. Nr.	Material	kg
93 15 10	■ 16 x 8	0,60

Zierelement "City", mit Kugel

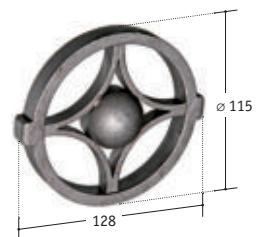

Art. Nr.	Material	kg
93 15 11	■ 16 x 8	0,70

Abdeckrossette "City"

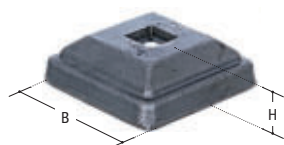

Art. Nr.	für Stab	B x H	kg
93 15 14	■ 14	60 x 20	0,19
93 15 15	■ 25	92 x 30	0,22

Zierhülse "City"

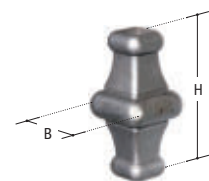

Art. Nr.	für Stab	B x H	kg
93 15 12	■ 14	42 x 85	0,31
93 15 13	■ 25	65 x 130	0,42

SCHMIEDEEISEN DESIGNSERIE »AKZENT«



Geländerstäbe

347

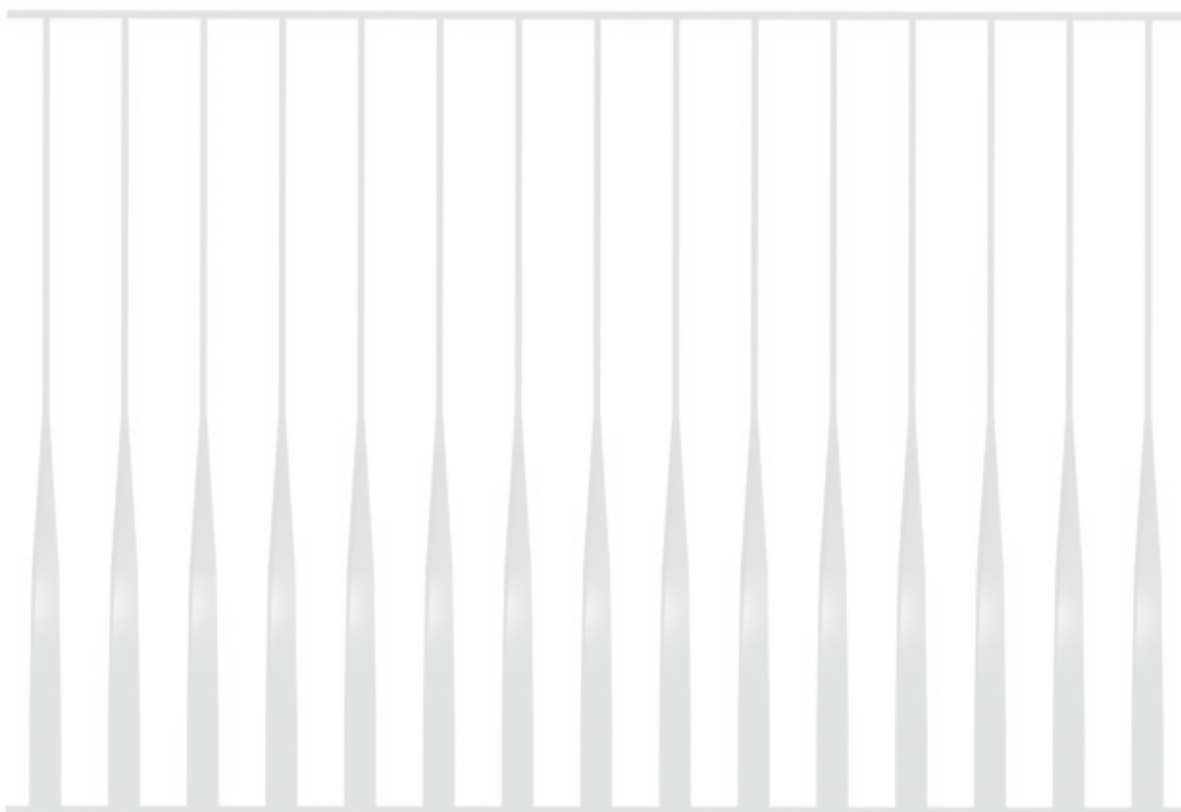

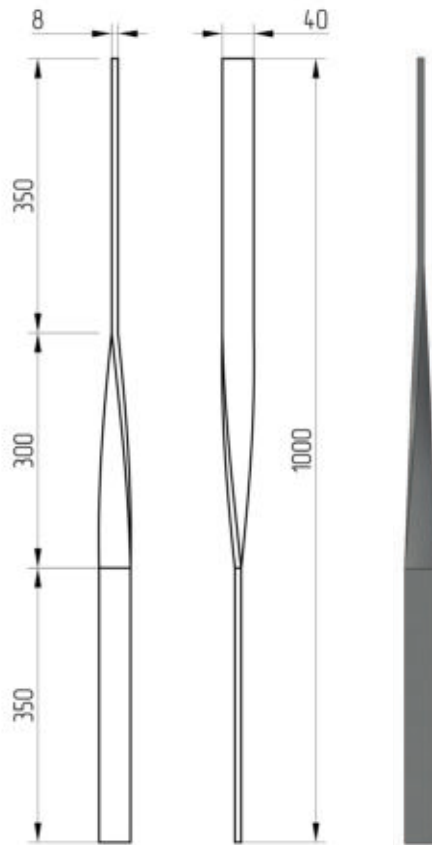

Geländerstab »Akzent-1«,
aus Flacheisen 40 x 10 mm,
Länge: 1000 mm, glatt,
mittig 90° gedreht

Art. Nr.

93 81 10

Anwendungsbeispiel

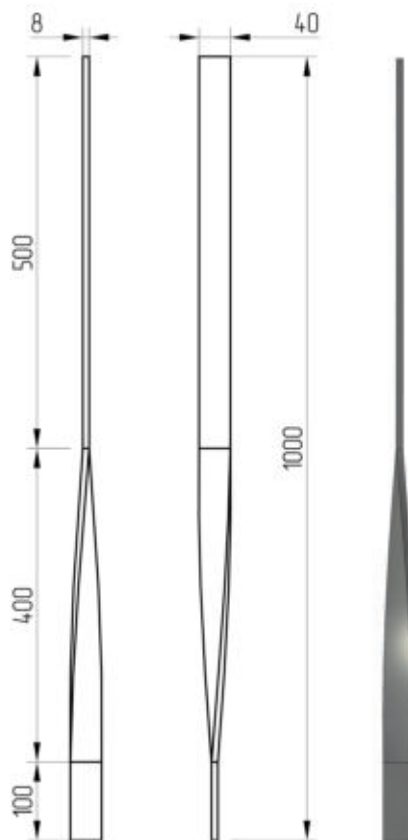
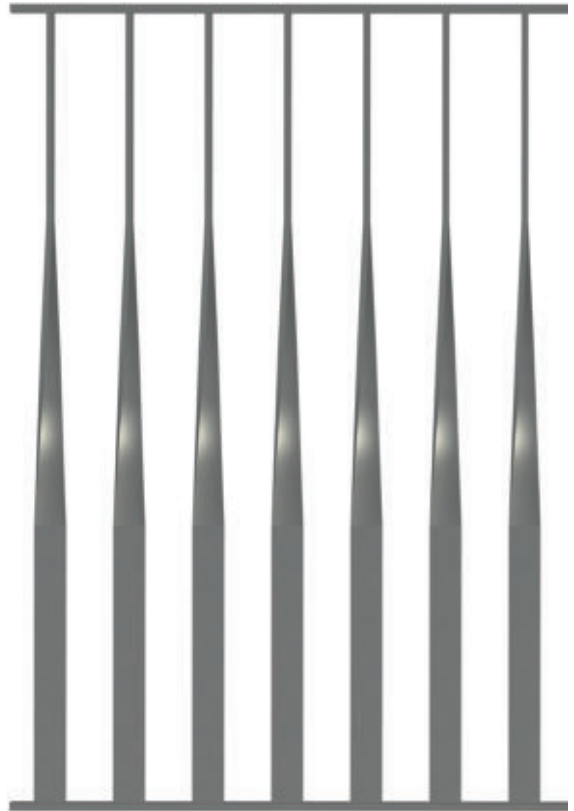

Geländerstab »Akzent-2«,
aus Flacheisen 40 x 10 mm,
Länge: 1000 mm, glatt,
asymmetrisch, nicht mittig,
90° gedreht

Art. Nr.

93 81 11

Anwendungsbeispiel

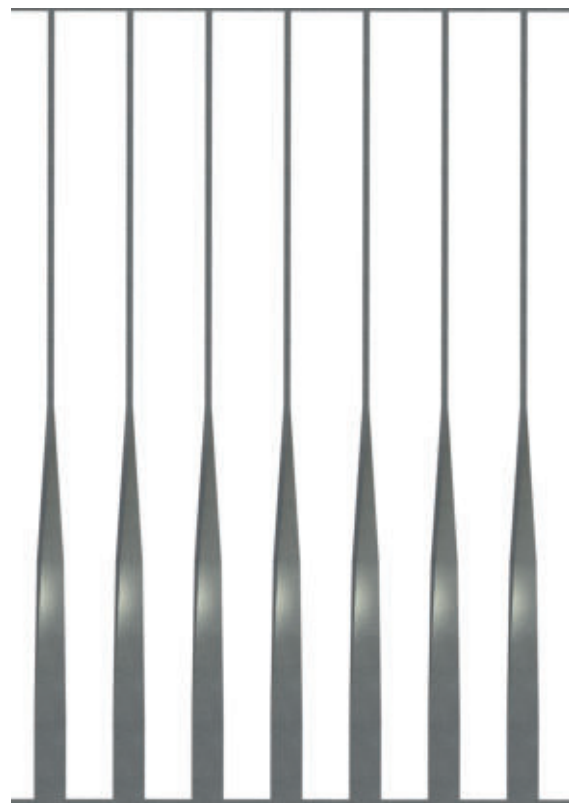

SCHMIEDEEISEN DESIGNSERIE »RONDE«

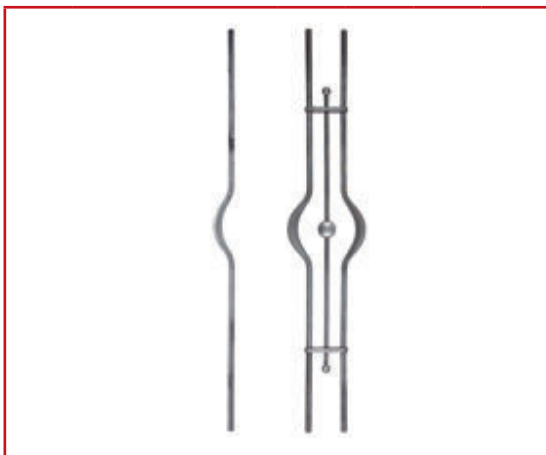

Designstäbe

349 - 351





Zierhülsen

351

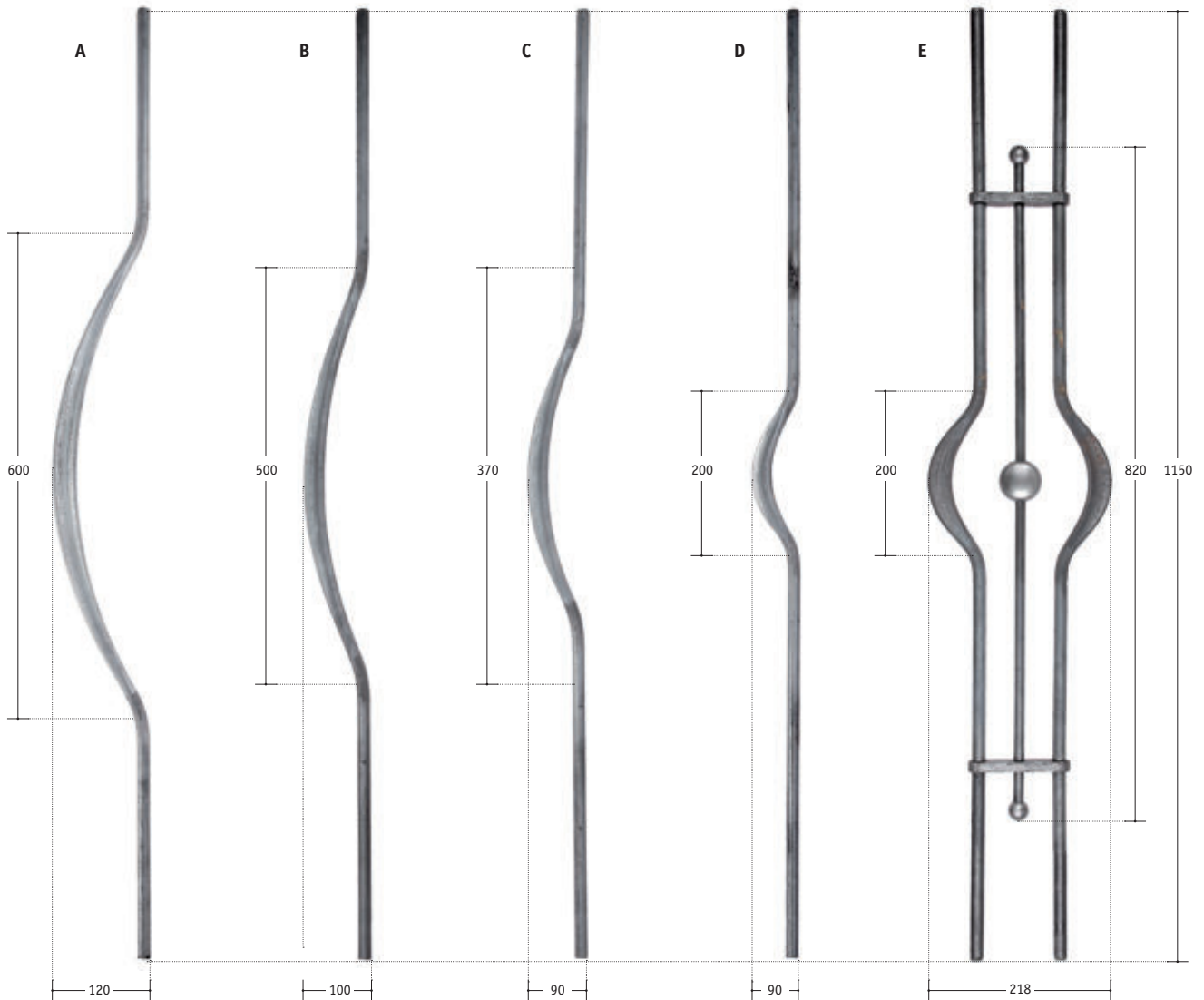
Geländerstäbe, Länge: 1150 mm,  glatt



Art. Nr. 93 16 00
 | ● 16 | 1,85 kg
L: 1150 mm

Art. Nr. 93 16 01
 | ● 16 | 1,84 kg
L: 1150 mm

Art. Nr. 93 16 02
 | ● 16 | 1,83 kg
L: 1150 mm

Art. Nr. 93 16 03
 | ● 16 | 1,83 kg
L: 1150 mm

Art. Nr. 93 16 04
 | ● 16 | 5,16 kg
L: 1150 mm

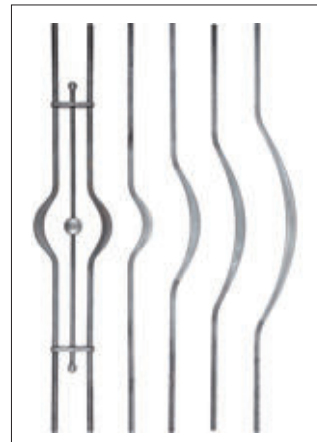
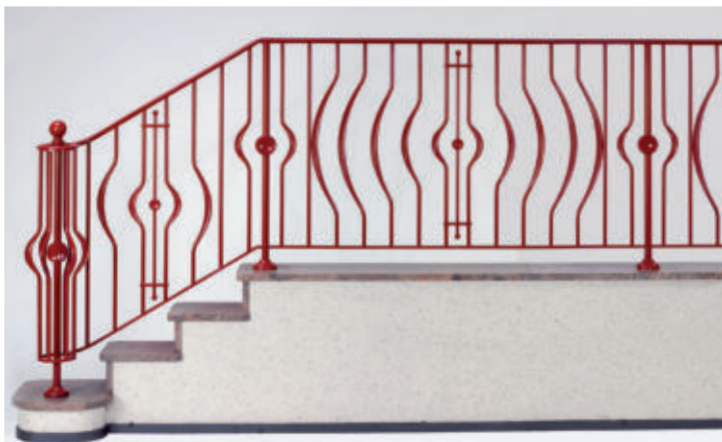

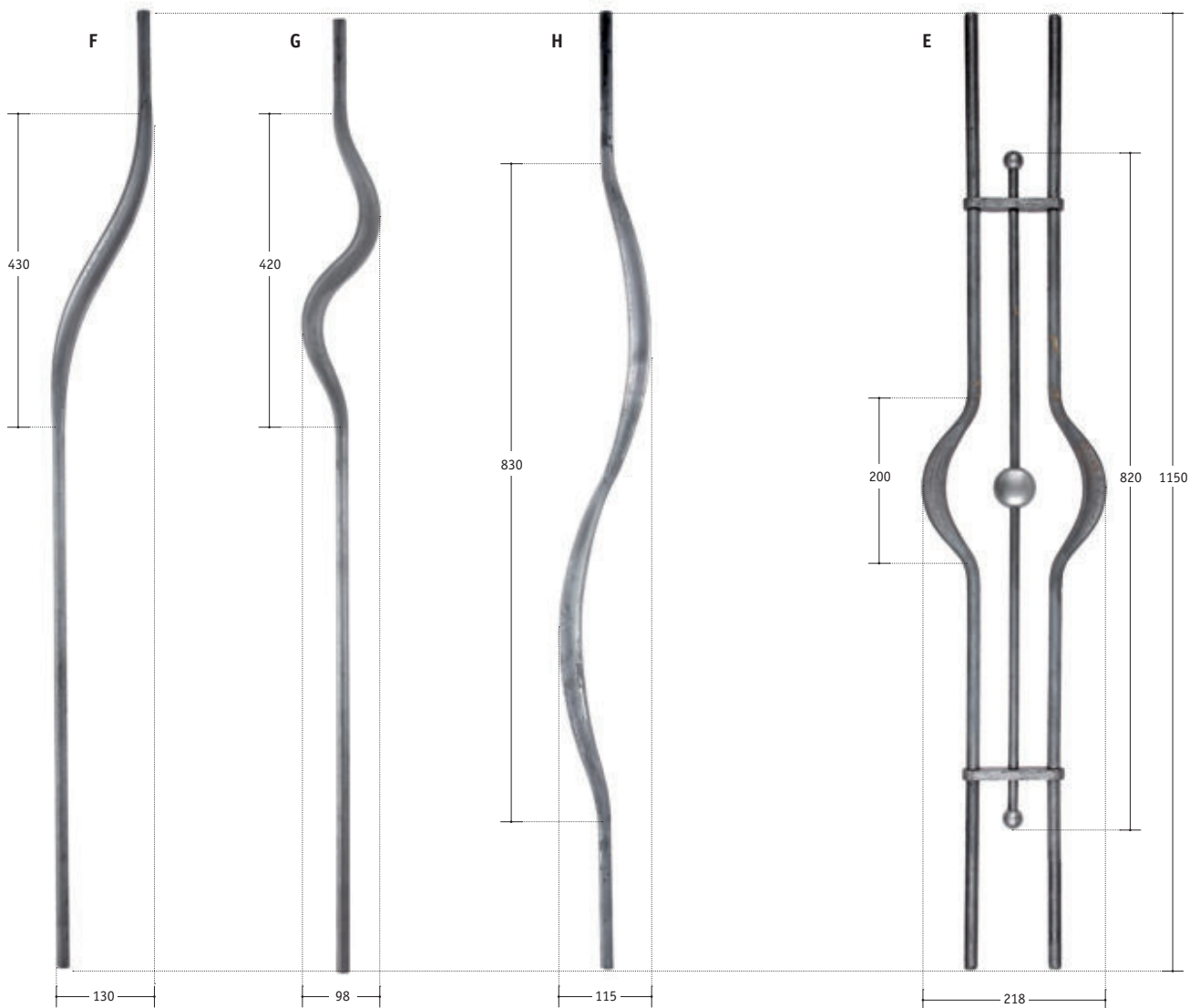

Art. Nr. 93 16 07
 | ● 16 | 1,76 kg
L: 1150 mm

Art. Nr. 93 16 08
 | ● 16 | 1,85 kg
L: 1150 mm

Art. Nr. 93 16 09
 | ● 16 | 1,83 kg
L: 1150 mm

Art. Nr. 93 16 04
 | ● 16 | 5,16 kg
L: 1150 mm



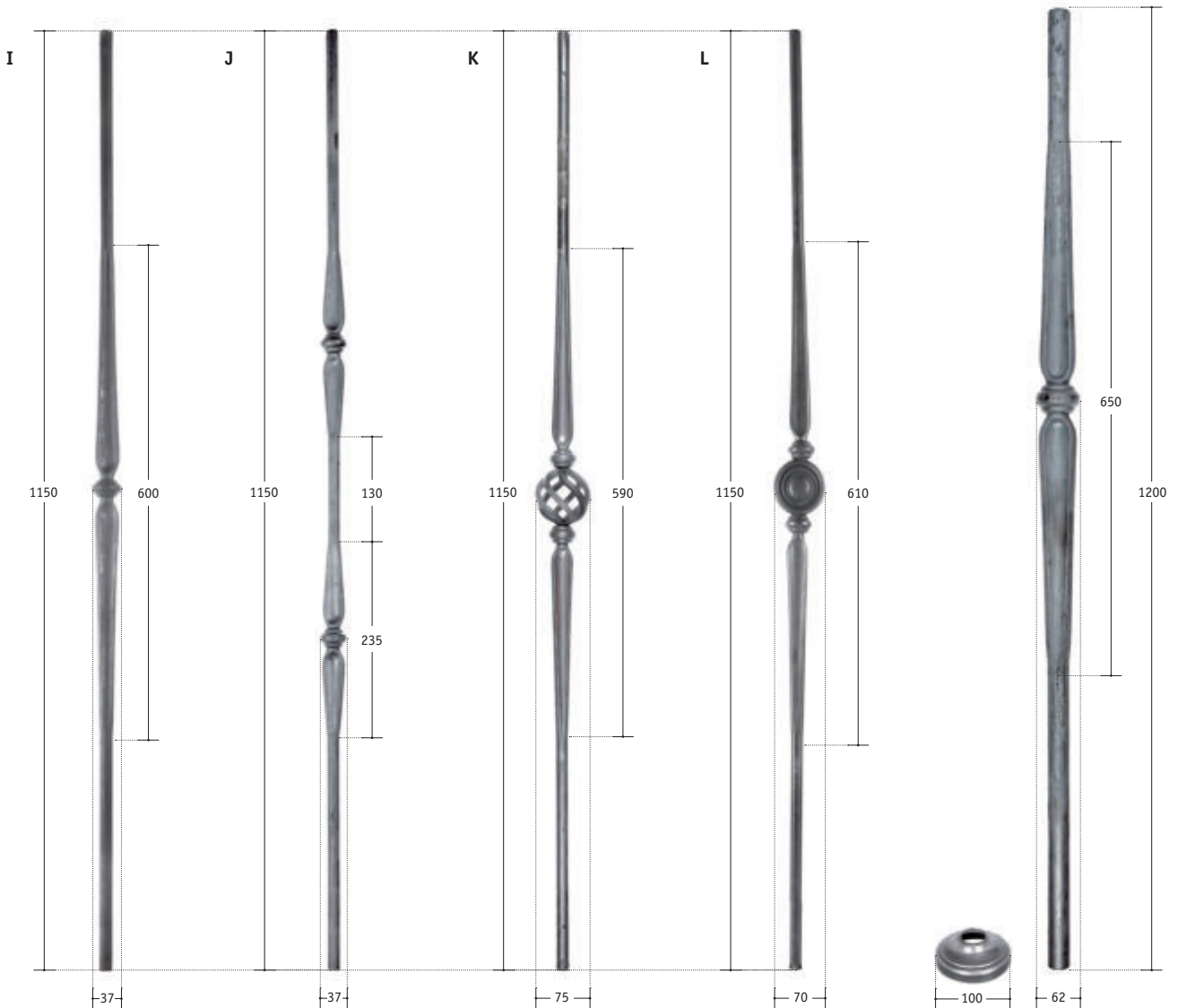

Geländerstäbe, Länge: 1150 & 1200 mm,  glatt



Art. Nr. 93 16 10
 | ● 16 | 1,88 kg
L: 1000 mm

Art. Nr. 93 16 11
 | ● 16 | 2,01 kg
L: 1000 mm

Art. Nr. 93 16 12
 | ● 16 | 2,15 kg
L: 1000 mm

Art. Nr. 93 16 13
 | ● 16 | 2,20 kg
L: 1000 mm

Art. Nr. 93 16 14
 | ● 30 | 7,15 kg
L: 1200 mm
inkl. Abdeckrosette

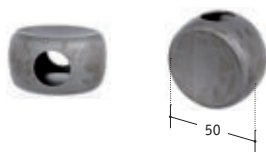

Designzierhülse „Ronde“, klein

Art. Nr.	für Stab	kg
93 16 05	∅ 12	0,238

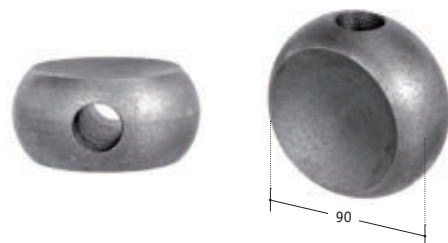

Designzierhülse „Ronde“, groß

Art. Nr.	für Stab	kg
93 16 06	∅ 30	0,340

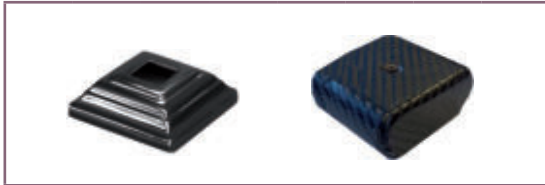

Elemente »CARBONE« 354 - 355

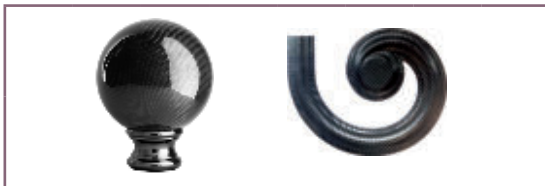

Elemente »CARBONE« 355



Stäbe »BLACK DIAMOND« 356 - 357

DESIGNSERIEN

»CARBONE« & »BLACK DIAMOND«

Bitte beachten Sie:

Die in diesem Kapitel angebotenen Artikel sind teilweise keine Lagerartikel (bitte Lieferzeiten erfragen).

»Carbone« & »Black Diamond« nur für den Innenbereich geeignet.



DESIGNSERIE »CARBONE«

Designserie »CARBONE« nur für den Innenbereich geeignet!

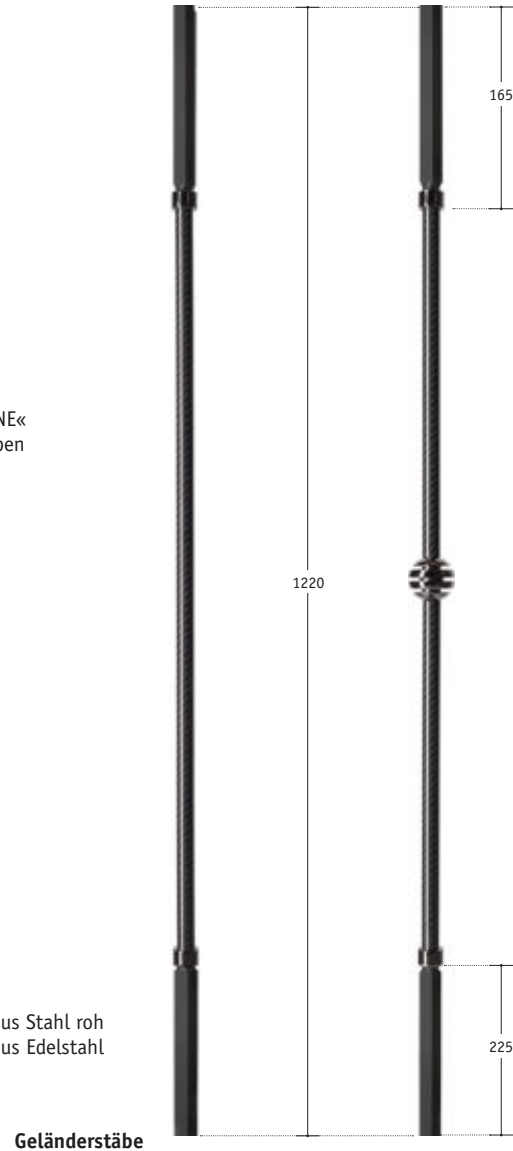
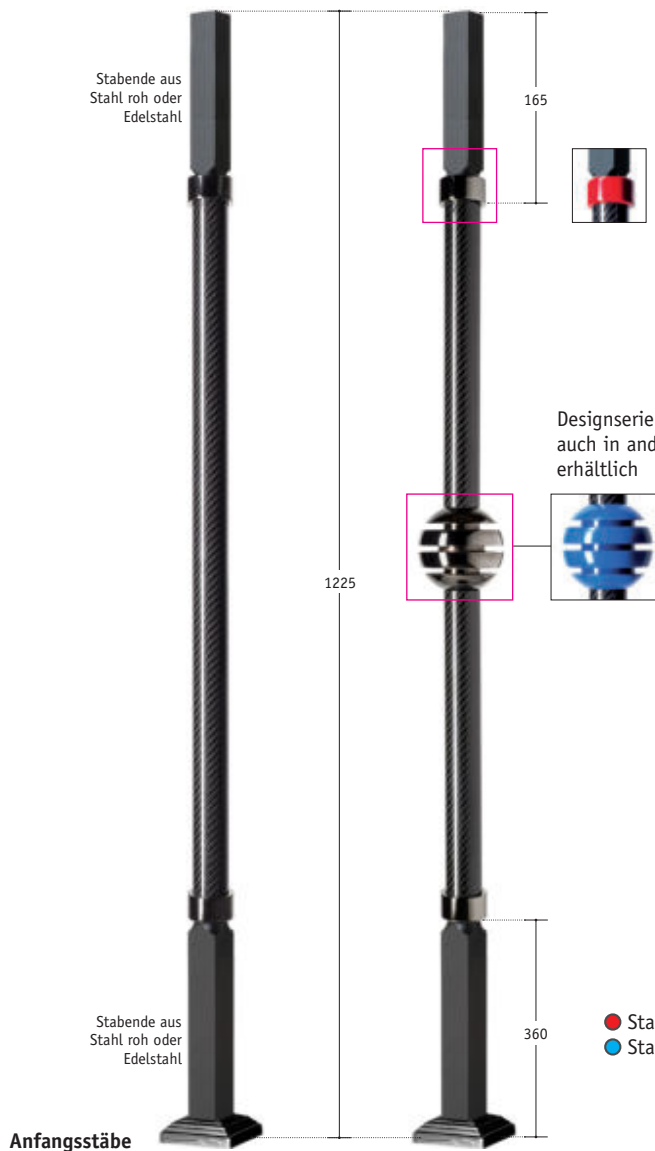

Art. Nr. 93 17 00
● Stahl roh | ● 40

Art. Nr. 93 17 01
● V2A | ● 42,4

Art. Nr. 93 17 02
● Stahl roh | ■ 35

Art. Nr. 93 17 03
● Stahl roh | ● 40

Art. Nr. 93 17 04
● V2A | ● 42,4

Art. Nr. 93 17 05
● Stahl roh | ■ 35

Art. Nr. 93 17 06
● Stahl roh | ● 16

Art. Nr. 93 17 07
● V2A | ● 16

Art. Nr. 93 17 08
● Stahl roh | ■ 16

Art. Nr. 93 17 09
● Stahl roh | ● 16

Art. Nr. 93 17 10
● V2A | ● 16

Art. Nr. 93 17 11
● Stahl roh | ■ 16

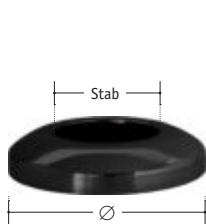

Abdeckrosette für Stäbe

Art. Nr.	für Stab	Ø
93 17 14	● 16	63
93 17 15	● 40	120
93 17 16	● 42,4	80

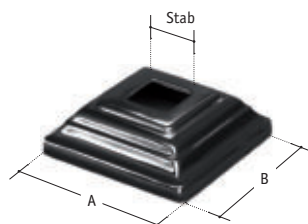

Abdeckrosette für Stäbe

Art. Nr.	für Stab	A x B
93 17 17	■ 16	60 x 60
93 17 18	■ 35	85 x 85



Abdeckrosette für Stäbe

Art. Nr.	für Stab	Ø
93 17 19	● 16	63
93 17 20	● 40	120
93 17 21	● 42,4	80

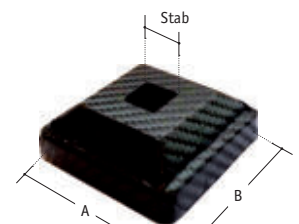

Abdeckrosette für Stäbe

Art. Nr.	für Stab	Maße
93 17 22	■ 16	60 x 60
93 17 23	■ 35	92 x 92

Designserie »CARBONE« nur für den Innenbereich geeignet!



Bitte beachten Sie:

Die in diesem Kapitel angebotenen Artikel sind teilweise keine Lagerartikel (bitte Lieferzeiten erfragen).

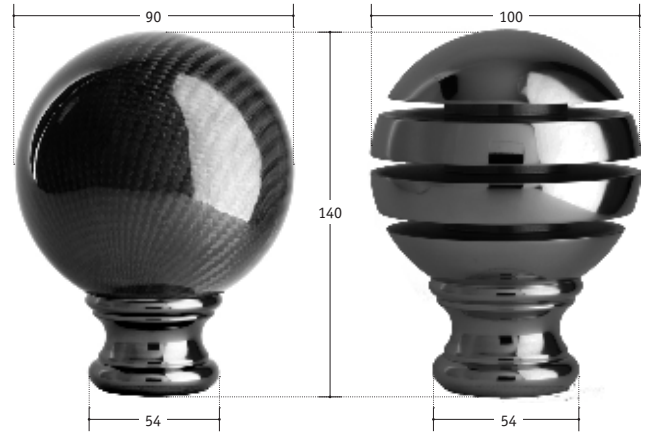

Aufsatzkugel

Art. Nr.

93 17 12

Aufsatzkugel

Art. Nr.

93 17 13



Handlaufträger mit Rosette

Art. Nr.

93 17 26

Träger Ø

● 16



Fugenabdeckbund

Art. Nr.

93 17 33

für Profil

■ 44 x 14



Profil-Endstück

Art. Nr.

93 17 35

für Profil

■ 44 x 14

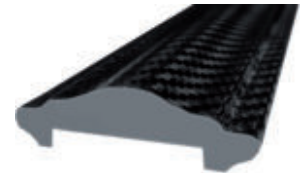

Handlauf

Art. Nr.

93 17 34

Profil

■ 44 x 14

Länge

3000 mm

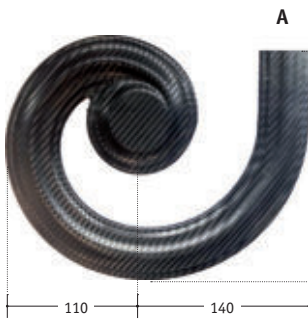

Handlauf-Anfangsstück

Art. Nr.

A 93 17 24

Profil

■ 44 x 14

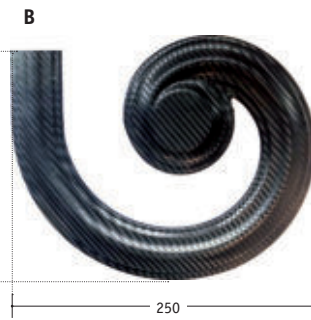

Handlauf-Anfangsstück

Art. Nr.

B 93 17 25

Profil

■ 44 x 14

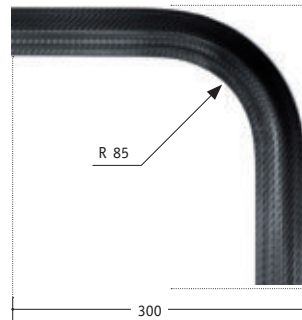

Handlauf-Winkelement

Art. Nr.

93 17 27

Profil

■ 44 x 14



Handlauf-Bogenelement

Art. Nr.

93 17 28

Profil

■ 44 x 14

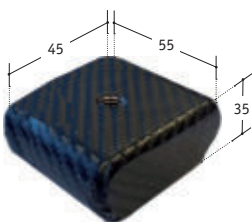

Pfostenabschluss,
mit Gewinde M10

Art. Nr.

93 17 30

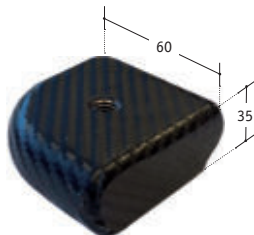

Pfostenabschluss,
mit Gewinde M10

Art. Nr.

93 17 31

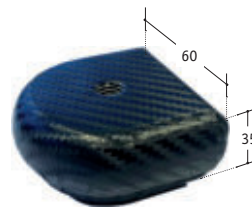

Pfostenabschluss,
mit Gewinde M10

Art. Nr.

93 17 32



Selbstklebende
Carbon-3D-Folie, Meterware

Art. Nr.

93 17 29

Breite

120 mm

Designstäbe »Black Diamond«

Alle Maßangaben sind Zirka-Maße.
Irrtümer und technische Änderungen vorbehalten.
Stand 10-2021

DESIGNSERIE »BLACK DIAMOND«

Designserie »Black Diamond«: Stahl - mattschwarz

Designserie »BLACK DIAMOND« nur für den Innenbereich geeignet.

Anfangsstäbe



Art. Nr. 93 16 20
inkl. Abdeckrosette
oben ■ 30 x 30
unten ■ 35 x 35

Art. Nr. 93 16 21
inkl. Abdeckrosette
oben ■ 30 x 30
unten ■ 35 x 35

Geländerstäbe



Art. Nr. 93 16 22
■ 16 x 16

Art. Nr. 93 16 23
■ 16 x 16

Detailansichten Designstäbe »BLACK DIAMOND«

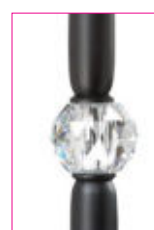
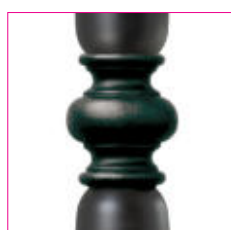
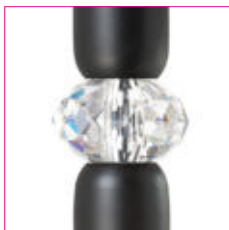

Designserie »BLACK DIAMOND« nur für den Innenbereich geeignet.

Designserie »Black Diamond - Modern«: Stahl - schwarz satiniert

Bitte beachten Sie:

Die in diesem Kapitel angebotenen Artikel sind teilweise keine Lagerartikel (bitte Lieferzeiten erfragen).

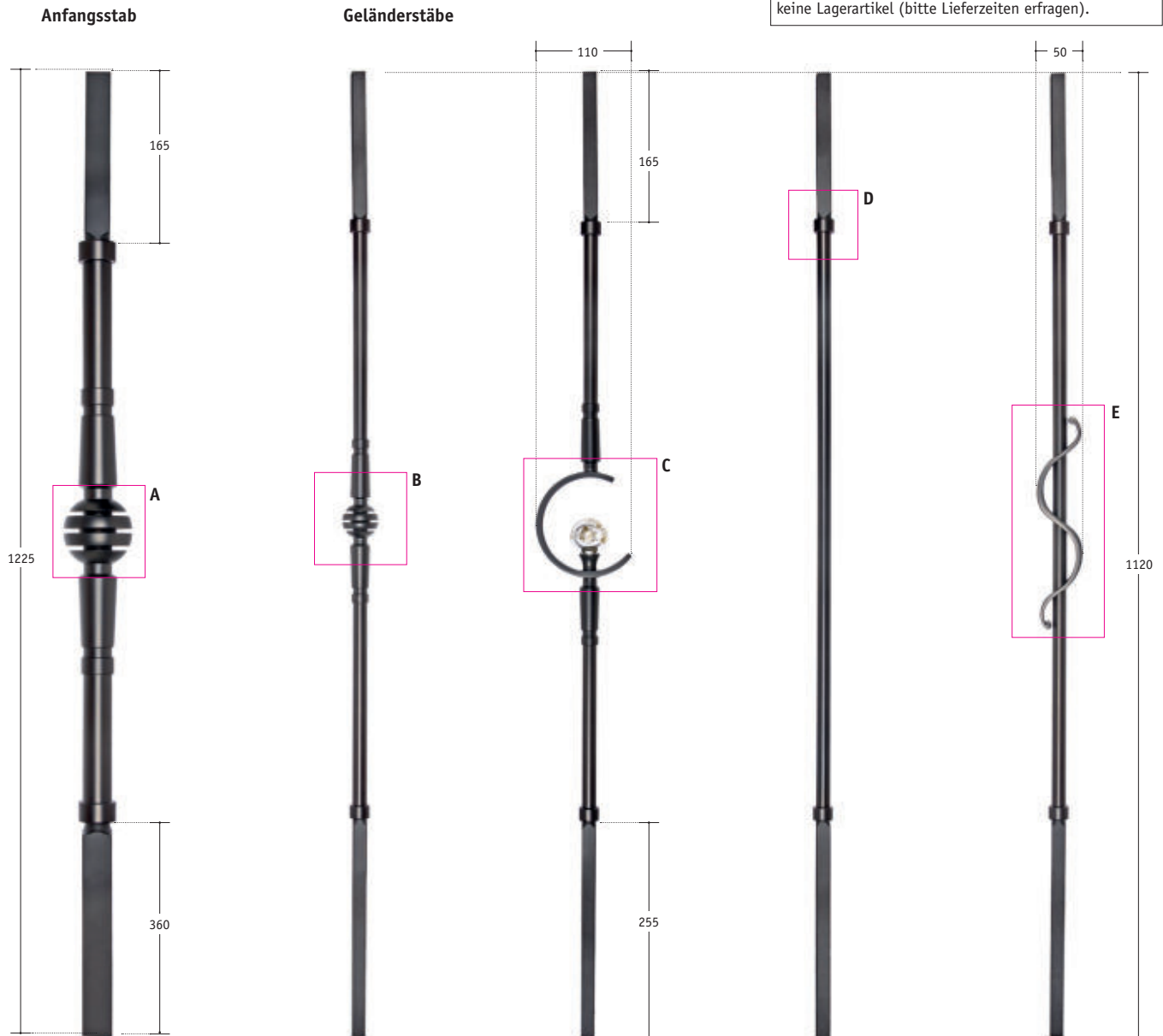

Art. Nr. 93 16 54

oben ■ 30 x 30

unten ■ 35 x 35

Art. Nr. 93 16 50

■ 16 x 16

Art. Nr. 93 16 51

■ 16 x 16

Art. Nr. 93 16 52

■ 16 x 16

Art. Nr. 93 16 53

■ 16 x 16

Detailansichten Designstäbe »BLACK DIAMOND«



A



B



C



D



E